

## Brightness and temperature sensor Bluetooth

Order no.: 5466 02

### User manual

## 1 Safety instructions for button cells

This device or its accessories are supplied with button cells.

**Danger to life! Swallowing buttons can lead to severe internal burns within 2 hours and death. Keep button cells away from children.**

**Do not use devices if the battery compartment does not close securely and keep away from children.**

**If you suspect that a button cell has been swallowed or is in a part of the body, seek immediate medical attention.**

**Risk of chemical burns! Batteries can burst and leak.**

**Do not short-circuit batteries. Replace batteries only with an identical or equivalent type.**

**Risk of explosion! Do not throw batteries into fire or recharge batteries.**

**These instructions are an integral part of the product, and must remain with the end customer.**

## 2 Intended use

- Sensor for detecting brightness and temperature
- Operation with Bluetooth Venetian blind and timer switch from system 3000
- Adhesive mounting in the interior on windows

### Product characteristics

- Brightness and temperature measurement takes place once per minute
- Transmits the current brightness and temperature value every 5 minutes
- Transmits the brightness value if the brightness changes by more than 10% of the last transmitted value
- Transmits the current temperature value if the temperature changes by more than 0.2 K
- Expanded function system 3000 Bluetooth Venetian blind and timer switch: sun protection function, dusk and dawn
- Indicates low battery level
- Battery-powered device
- Commissioning with Gira System 3000 app

### 3 Commissioning

#### Insert battery

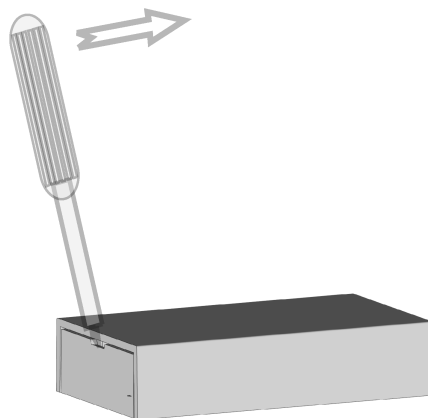

Figure 1: Open the housing

- Open the housing by sliding it apart. If necessary, use a narrow slot-headed screwdriver (Figure 1).

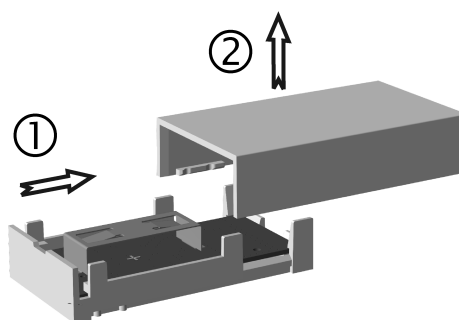
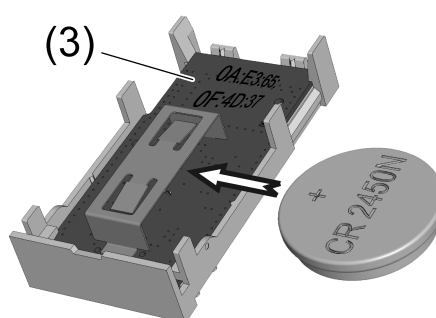

Figure 2: Raise housing lid

- Push the housing apart as far as it will go and lift the upper part upwards by tilting it sideways (Figure 2).
- i** Keep contacts of batteries and device free of grease.



\_\_\_ : \_\_\_ : \_\_\_ : \_\_\_ : \_\_\_ : \_\_\_

Figure 3: Inserting the battery

- Slide battery into battery holder (Figure 3). Observe polarity: the positive pole of the battery must be at the top.
- Note MAC address (3) (Figure 3). This address is required for assignment to the cover.

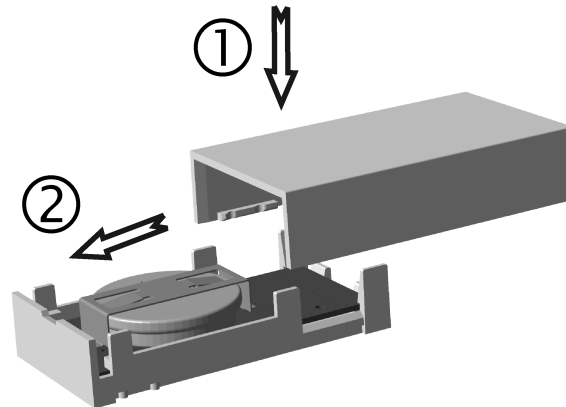

Figure 4: Close housing

- Reattach the housing lid and push the housing together until it locks into place. (Figure 4). The device is ready for operation.

#### Assigning the sensor to the cover

The sensor transmits the brightness and temperature values every 5 minutes and when the brightness or temperature changes. The sensor must be assigned to the cover so that it can process the measured values of the sensor. This assignment is done via the app.

- Select "Add sensor" in the app configuration.  
An input field for the MAC address of the device will appear in the app.
- Enter the MAC address (3) (Figure 3) in the input field.  
The actuator will now evaluate all received sensor telegrams.

## 4 Mounting



**Remove empty batteries immediately and dispose of in an environmentally friendly manner. Do not throw batteries into household waste. Consult your local authorities about environmentally friendly disposal. According to statutory provisions, the end consumer is obligated to return used batteries.**

#### Selecting installation location

To ensure good transmission quality, keep a sufficient distance from any possible sources of interference, e.g. metallic surfaces, microwave ovens, hi-fi and TV systems, ballasts or transformers.

Operation as brightness sensor: Select the installation location on the window pane so that the sunlight hits the sensor unobstructed even when the sun protection is active. Shadows produce incorrect measured values.

#### Mounting the sensor

The contact surface of the substrate must be dry, clean and free of grease.

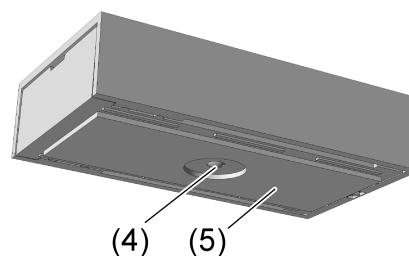

Figure 5: Underside of housing with adhesive pads

## Brightness and temperature sensor Bluetooth

- Apply adhesive pad (5) to underside of housing (Figure 5). Remove the protective film on one side, place it on the underside of the sensor housing and press it down firmly. The light guide (4) for brightness measurement must not be pasted over.
- Remove the protective film from the adhesive pad, place the sensor on the surface and press firmly.

**Dismounting the sensor**

- Detach the sensor from the surface by rotating it alternating clockwise and counterclockwise.

**5 Technical data**

Rated voltage	DC 3 V
Battery type	1×lithium CR 2450
Brightness measurement	5 ... 80,000 lx
Temperature measurement	-5 ... +55 °C
Ambient temperature	-5 ... +55 °C
Storage/transport temperature	-20 ... +70 °C
Dimensions L×W×H	56 x 32 x 13 mm
Transmitting range	typ. 10 m
Radio frequency	2.402 ... 2.480 GHz
Transmission capacity	max. 2.5 mW, Class 2

**6 Conformity**

Gira Giersiepen GmbH & Co. KG hereby declares that the radio system type order no. 5466 02 meets the directive 2014/53/EU. You can find the full article number on the device. The complete text of the EU Declaration of Conformity is available under the Internet address: [www.gira.de/konformitaet](http://www.gira.de/konformitaet)

**7 Warranty**

The warranty follows about the specialty store in between the legal framework as provided for by law Please submit or send faulty devices postage paid together with an error description to your responsible salesperson (specialist trade/installation company/electrical specialist trade). They will forward the devices to the Gira Service Center. They will forward the devices to the Gira Service Center.

**Gira**  
**Giersiepen GmbH & Co. KG**  
 Elektro-Installations-  
 Systeme

Industriegebiet Mermbach  
 Dahlienstraße  
 42477 Radevormwald

Postfach 12 20  
 42461 Radevormwald

Deutschland

Tel +49(0)21 95 - 602-0  
 Fax +49(0)21 95 - 602-191

[www.gira.de](http://www.gira.de)  
[info@gira.de](mailto:info@gira.de)