

Operating instructions

Button interface, 2-gang Standard
Art. no. 5182 00

Button interface, 4-gang Standard
Art. no. 5184 00

Button interface, 8-gang Standard
Art. no. 5188 00

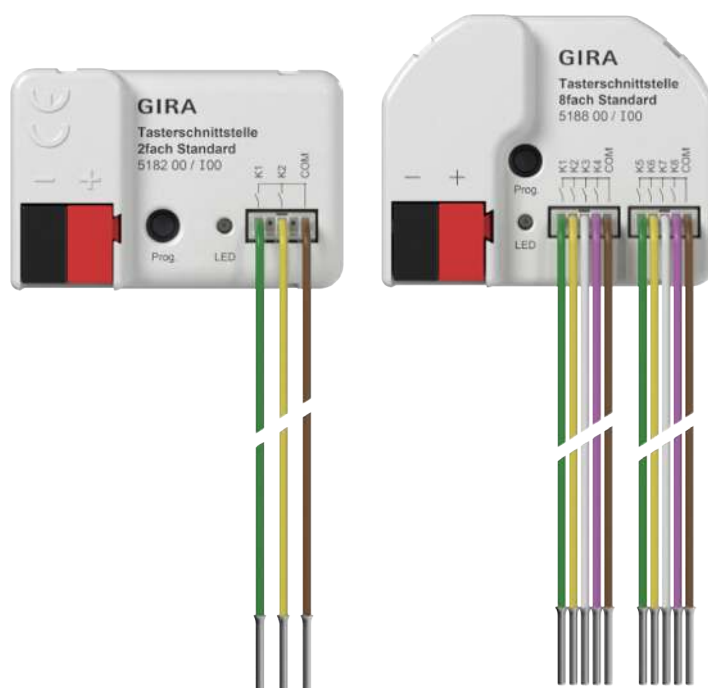

Table of contents

1 Safety instructions 3

2 System information 3

3 Intended use 3

4 Product characteristics 4

5 Mounting and electrical connection 5

6 Commissioning 6

 6.1 Safe-state mode and master reset..... 7

7 Technical data 7

8 Parameter list 9

9 Warranty 10

1 Safety instructions

To avoid potential damage, read and follow the following instructions:



Electric devices may only be mounted and connected by electrically skilled persons.

Danger of electric shock. Comply with the regulations and standards that apply to SELV circuits during the installation and cable routing.

Danger of electric shock on installation. Lines that carry FELV, PELV or mains voltage are not permitted in the installation area. The SELV potential on the bus line will no longer be available.

Danger of electric shock on installation. Do not connect any external voltage to the inputs. The device can become damaged, and the SELV potential on the bus line will no longer be available.

Instructions are part of the product. So keep them in a safe place.

2 System information

This device is a product for the Gira One Smart Home system. The Gira One system is commissioned easily and in a time-saving manner using the Gira Project Assistant.

The Gira One Smart Home system enables the control and automation of lighting, heating and shading, as well as connection to various third-party systems and much more. It can be operated via Gira One switches, by app from home or securely from a remote location. Electrically skilled persons can maintain the Gira One project remotely free of charge.

Data transmission between the Gira One devices is encrypted. This provides protection against third-party access and manipulation.

Commissioning is carried out with the free Gira Project Assistant (GPA), version 5.x or higher. Free function and security updates are also transferred to the Gira One devices with the GPA.

The Gira One system is based on the globally proven KNX smart home standard.

3 Intended use

- Operation in Gira One system
- Inputs for polling conventional, potential-free contacts in Gira One systems and for sending telegrams to the bus for signalling of statuses, meter readings, operation of loads, etc.
- Mounting in appliance box with dimensions according to DIN 49073 in combination with a suitable cover
- When mounting behind switch inserts and push-button inserts, use an appliance box with sufficient installation depth

4 Product characteristics

- Inputs: Connection of potential-free contacts such as push-buttons, switches and Reed contacts or smoke detectors.
- The inputs are used to activate Gira One actuators or to record status information.
- Impulse current for avoiding contact fouling (image an oxide layer) at the connected contacts
- The inputs are used to activate Gira One actuators or to record status information.
- Two, four or eight independent inputs, depending on the variant.
- Commissioning of push-button interfaces, Index 01 or higher, with Gira Project Assistant (GPA) version 5.2
- Encrypted data transmission between the Gira One devices.

Inputs

- Single or dual-area operation can be configured for rockers.
- Connection of rockers that are configured with the function for switching, dimming, shading and ventilation, scene recall, staircase (motion detector), floor call with Gira G1, garage door and door opener.
- Connection of potential-free contacts.
- Convenient group control of switching, dimming, shading and ventilation loads.
- Switching contact evaluation of wind, frost, brightness or rain sensors with potential-free relay outputs possible in order to protect shading and ventilation loads against environmental influences.
- Window contact polling and visualisation in the Smart Home app: An open window leads to the frost protection heating operating mode after 5 minutes have elapsed.
- Door contact polling and visualisation in the Smart Home app: An open door leads to the Venetian blind or shutters being raised and locked.
- Polling of a switch-over between heating/cooling at a heat pump in order to be able to forward the current operating mode (heating or cooling) to a heating controller.
- Switching contact indicator for displaying a contact state in the Smart Home app.

5 Mounting and electrical connection

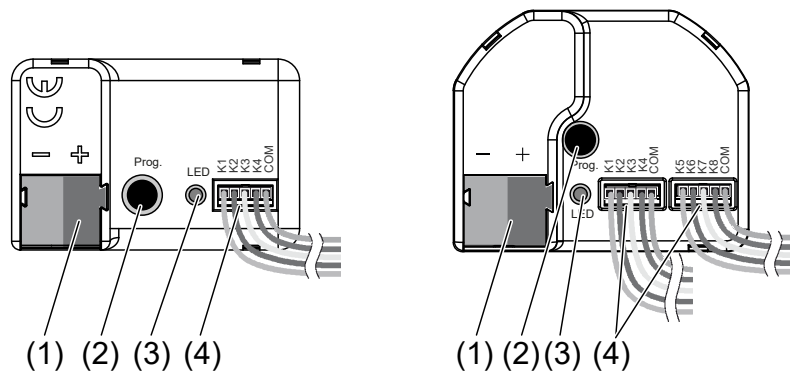

Figure 1: Device components

- (1) Bus connection
- (2) Programming button
- (3) Programming LED
- (4) Connection cables

Installation instructions

- To avoid interference from EMC radiation, the cables of the inputs should not be run in parallel to cables carrying mains voltage or to load cables.
- The voltage potentials of the connecting cables for the inputs and outputs are not galvanically isolated from the bus voltage. The connection cables effectively extend the bus line. The specification for the bus cable length (max. 1000 m) must be observed.
- Do not connect the **COM** connections of multiple push-button interfaces.

For the extension of the enclosed cable set (see figure 2), observe the maximum cable length l (max. 10 m). The following applies: the COM cable for each cable set must not exceed the total maximum length of l .

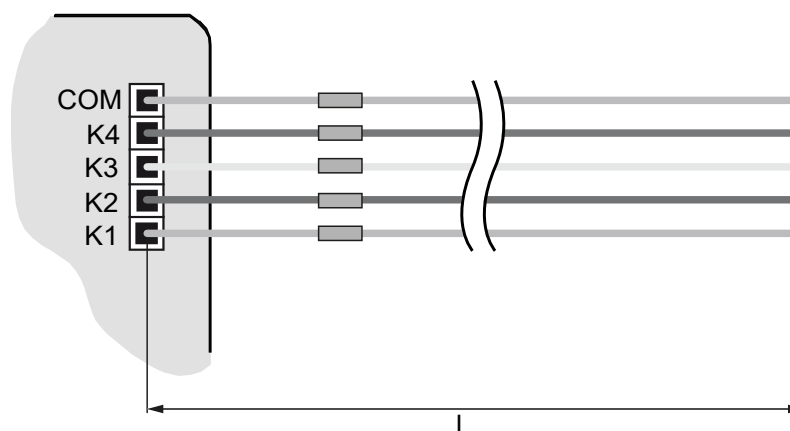

Figure 2: Maximum cable length

Mounting and connecting the device

- Connect bus line with device connection terminal observing the correct polarity (red = +, black = -) (see figure 1).
- Enter or scan the device certificate and add it to the project. A high resolution camera should be used to scan the QR code.
- Recommendation: Remove the device certificate from the device during mounting.
- Document all passwords and keep them safe.
- Mounting in suitable appliance box. Observe cable routing and spacing



DANGER!

Danger of electrical shock when mains voltage 230 V or other external voltages are connected!

Electric shocks can be fatal.

Device may be destroyed.

Only connect potential-free push-buttons, switches or contacts.

- Connect push-buttons, switches or contacts to enclosed connecting cables (4) according to the connection example (see figure 3).

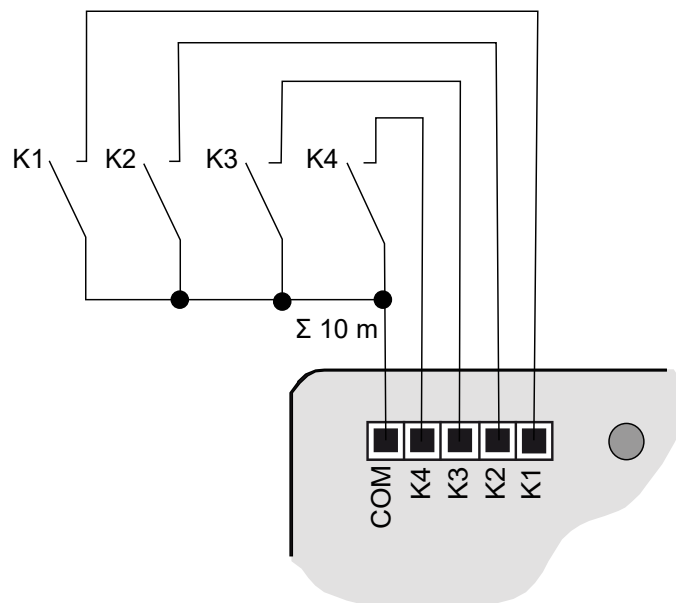

Figure 3: Connection example, 4-gang

6 Commissioning

Commissioning

Commissioning is carried out with the Gira Project Assistant (GPA), version 5.2 or higher, by scanning the device certificate.

6.1 Safe-state mode and master reset

Safe-state mode

The safe-state mode stops the execution of the program. Only the system software of the device is still functional. Diagnosis functions and programming of the device are possible.

Activating safe-state mode

- Switch off the bus voltage or remove the device connection terminal of the bus.
- Wait approx. 10 seconds.
- Press and hold down the programming button.
- Switch on the bus voltage or attach the device connection terminal of the bus.
- Wait until the programming LED flashes slowly.
- Release the programming button.

Safe-state mode is activated.

Deactivating safe-state mode

- Switch off bus voltage (wait approx. 10 seconds) or carry out the programming process.

Master reset

The master reset restores the basic device settings (firmware remains in place). The device must then be recommissioned with the GPA.

Performing a master reset

Prerequisite: safe-state mode is activated.

- Press and hold down the programming button for > 5 s.

The programming LED flashes quickly.

- Release the programming button.

The programming LED is illuminated. The device performs a master reset and restarts.

The programming LED goes out after approx. 5 s. The device is ready for operation again.

7 Technical data

Ambient temperature	-5 ... +45 °C
Storage/transport temperature	-25 ... +75 °C
Degree of protection	IP20

Protection class	III
Number of channels	
5182 00	2
5184 00	4
5188 00	8
Output voltage	DC 3.3 V SELV
Output current per channel	max. 3.3 mA
Connection of channels	
5182 00	3-core wiring harness
5184 00	5-core wiring harness
5188 00	2x 5-core wiring harness
Length, wiring harness	25 cm, can be extended to max. 10 m
Recommended cable	J-Y(St)Y 2×2×0.8
Dimensions (WxHxD)	
5182 00, 5184 00	43.0 x 28.5 x 15.4 mm
5188 00	43.5 x 35.5 x 15.4 mm
Rated voltage	DC 21 ... 32 V SELV
Current consumption, bus	
5182 00	4 ... 7 mA
5184 00	4 ... 9 mA
5188 00	4 ... 12 mA
Connection bus	Device connection terminal

8 Parameter list

Parameters that can be set via the GPA:

Input

Debounce time	10 ... 255 ms
This parameter sets the debouncing time individually for the input. According to the time set here, the input signal at the input is evaluated with a delay.	
Contact type	NO contact NC contact
The contact type of the connected contact is defined here.	
When closing the contact	No reaction Switch on Switch off Toggle
This parameter determines the reaction when the contact connected to the input is closed.	
When opening the contact	No reaction Switch on Switch off Toggle
This parameter determines the reaction when the contact connected to the input is opened.	

9 Warranty

The warranty is provided by the specialist trade in accordance with statutory requirements. Please submit or send faulty devices postage paid together with a fault description to your responsible salesperson (specialist trade / installation company / electrical specialist trade). They will forward the devices to the Gira Service Center.

Gira
Giersiepen GmbH & Co. KG
Elektro-Installations-
Systeme

Industriegebiet Mermbach
Dahlienstraße
42477 Radevormwald

Postfach 12 20
42461 Radevormwald

Deutschland

Tel +49(0)21 95 - 602-0
Fax +49(0)21 95 - 602-191

www.gira.de
info@gira.de