

Operating instructions

Button interface, 2-gang Standard
 Art. no. 5182 00

Button interface, 4-gang Standard
 Art. no. 5184 00

Button interface, 8-gang Standard
 Art. no. 5188 00

Button interface, 2-gang Komfort
 Art. no. 5192 00

Button interface, 4-gang Komfort
 Art. no. 5194 00

Button interface, 8-gang Komfort
 Art. no. 5198 00

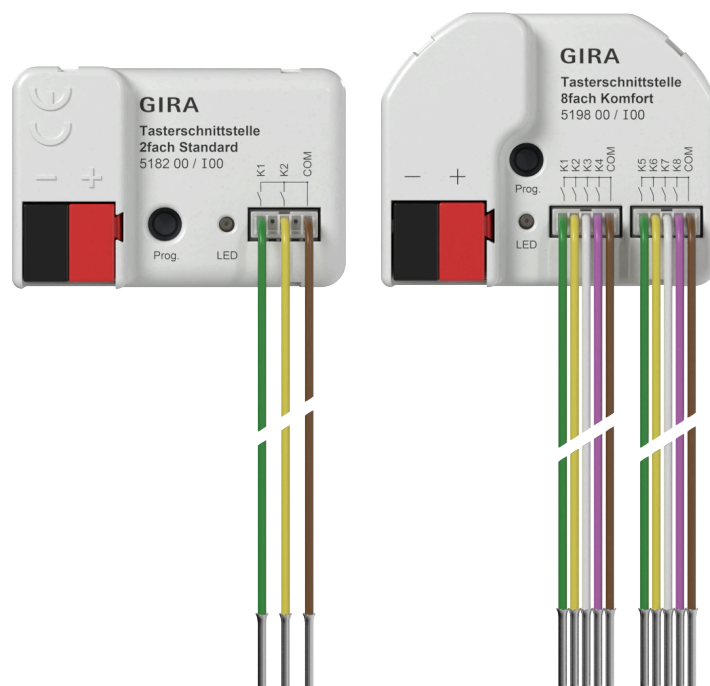

Table of contents

1	Safety instructions	3
2	System information	3
3	Intended use	3
4	Product characteristics	4
5	Mounting and electrical connection	5
6	Commissioning	8
6.1	Safe-state mode and master reset.....	8
7	Technical data	10
8	Accessories	11
9	Warranty	11

1 Safety instructions

To avoid potential damage, read and follow the following instructions:



Electric devices may only be mounted and connected by electrically skilled persons.

Danger of electric shock. Comply with the regulations and standards that apply to SELV circuits during the installation and cable routing.

Danger of electric shock on installation. Lines that carry FELV, PELV or mains voltage are not permitted in the installation area. The SELV potential on the bus line will no longer be available.

Danger of electric shock on installation. Do not connect any external voltage to the inputs. The device can become damaged, and the SELV potential on the bus line will no longer be available.

Instructions are part of the product. So keep them in a safe place.

2 System information

This device is a product of the KNX system and complies with the KNX directives. Detailed technical knowledge obtained in KNX training courses is a prerequisite for proper understanding.

The function of the device depends on the software. Detailed information on software versions and the respective scope of functions as well as the software itself can be obtained from the manufacturer's product database.

The device can be updated. The firmware is easy to update with the Gira ETS Service app (additional software).

The device is KNX Data Secure capable. KNX Data Secure offers protection against manipulation in building automation and can be configured in the ETS project. Detailed technical knowledge is a prerequisite. A device certificate, which is attached to the device, is required for safe commissioning. During mounting, the device certificate must be removed from the device and stored securely.

Planning, installation and commissioning of the device are carried out with the aid of the ETS, version 5.7.7 and higher or 6.1.0

3 Intended use

- Operation in KNX system for Standard and Comfort devices.
- Inputs for polling conventional, potential-free contacts in KNX systems and for sending telegrams to the bus for signalling of statuses, meter readings, operation of loads, etc.
- Outputs for activation of LEDs (KNX only)
- Mounting in appliance box with dimensions according to DIN 49073 in combination with a suitable cover

- When mounting behind switch inserts and push-button inserts, use an appliance box with sufficient installation depth

4 Product characteristics

- Depending on the variant, two, four or eight independent channels, which work as inputs or as outputs, depending on the configuration
- Common reference potential for all channels
- Disabling of individual channels
- Supply via bus, no additional supply voltage necessary

Outputs

- Connection of LEDs
- Short-circuit resistant, overload-protected and reverse-polarity protected
- Switching outputs in parallel possible, for loads with higher energy consumption

Inputs

- Connection of potential-free contacts such as push-buttons, switches or Reed contacts
- Impulse current for avoiding contact fouling (image an oxide layer) at the connected contacts
- Operating functions: switching, dimming, controlling of Venetian blinds, scenes or room temperature
- Value transmitter for dimming, colour temperature, RGBW, temperature and brightness values
- Transmission of the current input state after bus voltage failure

Additionally for comfort variant inputs

- Connection of door or window contacts for the evaluation of the status open, closed, tilted and grip position
- Connection of leakage, condensation and temperature sensors (see accessories)
- Pulse counter with main counter and intermediate counter
- Combination of adjacent input channels for connection of push-button, door contact and window contact
- Logic functions

5 Mounting and electrical connection

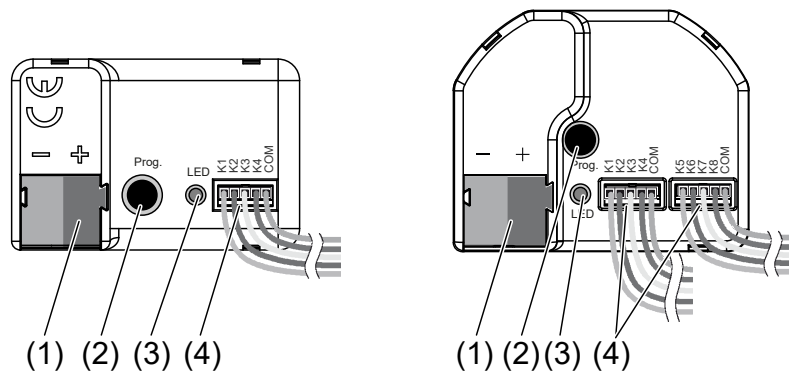

Figure 1: Device components

- (1) Bus connection
- (2) Programming button
- (3) Programming LED
- (4) Connection cables

Installation instructions

- To avoid interference from EMC radiation, the cables of the inputs should not be run in parallel to cables carrying mains voltage or to load cables.
- The voltage potentials of the connecting cables for the inputs and outputs are not galvanically isolated from the bus voltage. The connection cables effectively extend the bus line. The specification for the bus cable length (max. 1000 m) must be observed.
- Do not connect the **COM** connections of multiple push-button interfaces.
- Comfort variants: Use channels 1 and 2 for NTC temperature sensors (see chapter "Accessories" ▶ Page 11).
- No series resistance required for the connection of LEDs.

For the extension of the enclosed cable set (see figure 2), observe the maximum cable length I: 5182 00, 5184 00, 5188 00 max. 10 m, 5192 00, 5194 00, 5198 00 max, 30 m. The following applies: the COM cable for each cable set may not exceed the total maximum length of I.

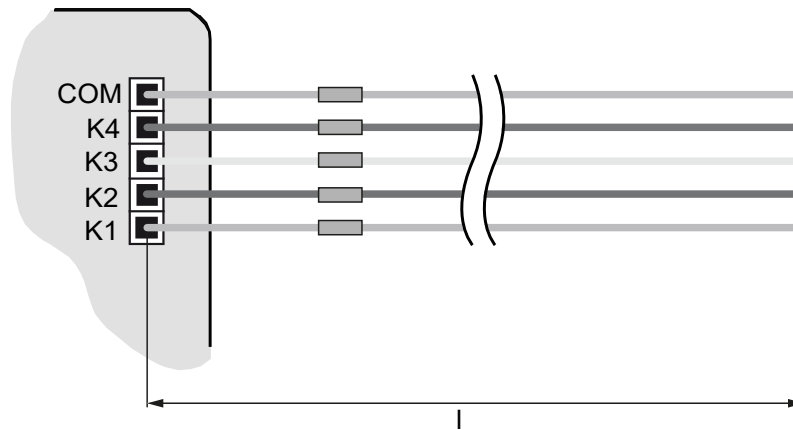

Figure 2: Maximum cable length

Mounting and connecting the device

- Connect bus line with device connection terminal observing the correct polarity (red = +, black = -) (see figure 1).
- Enter or scan the device certificate and add it to the project. A high resolution camera should be used to scan the QR code.
- Recommendation: Remove the device certificate from the device during mounting.
- Document all passwords and keep them safe.
- Mounting in suitable appliance box. Observe cable routing and spacing



DANGER!

Danger of electrical shock when mains voltage 230 V or other external voltages are connected!

Electric shocks can be fatal.

Device may be destroyed.

Only connect potential-free push-buttons, switches or contacts.

- Connect push-buttons, switches, contacts, LED or NTC to enclosed connecting cables (4) according to the connection examples; (see figure 3) to (see figure 5). The connection examples show the use with inputs, outputs and sensors.

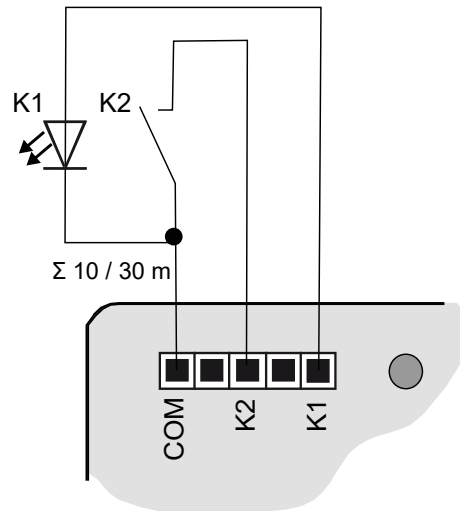

Figure 3: Connection example: push-button interface 2-gang

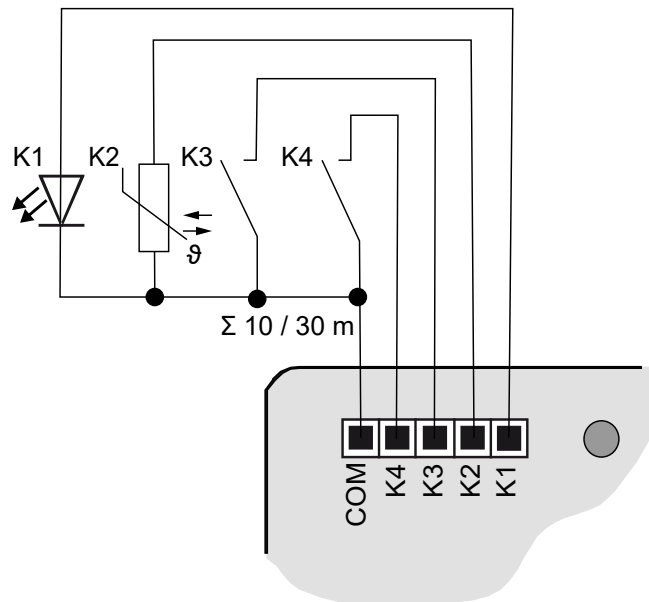

Figure 4: Connection example: push-button interface 4-gang

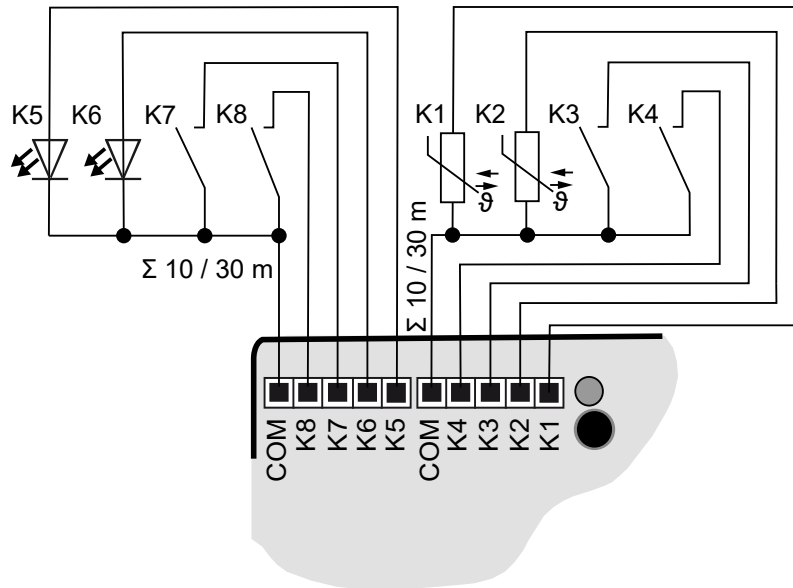

Figure 5: Connection example: push-button interface 8-gang

To increase the output current, outputs can also be switched parallel to each other with the same parameterization; in the example here, (see figure 6) K1-K3 are switched in parallel.

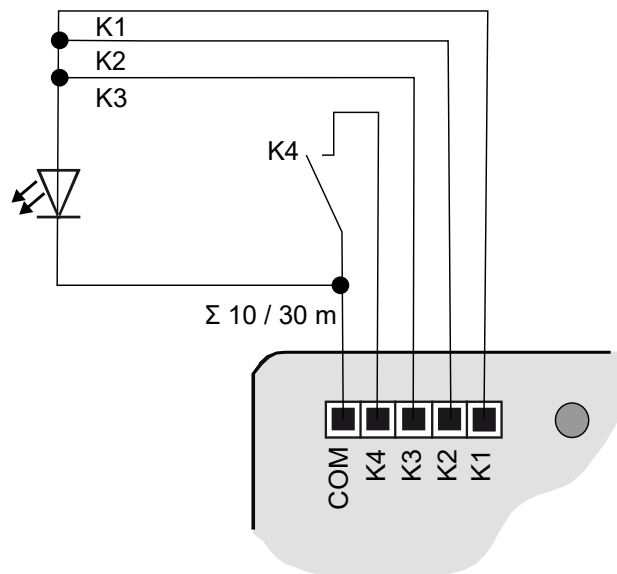

Figure 6: Connection example with outputs switched in parallel

6 Commissioning

6.1 Safe-state mode and master reset

Safe-state mode

The safe-state mode stops the execution of the loaded application program.

- i** Only the system software of the device is still functional. ETS diagnosis functions and programming of the device are possible.

Activating safe-state mode

- Switch off the bus voltage or remove the KNX device connection terminal.
- Wait approx. 10 seconds.
- Press and hold down the programming button.
- Switch on the bus voltage or attach the KNX device connection terminal.
- Wait until the programming LED flashes slowly.
- Release the programming button.

Safe-state mode is activated.

The programming mode can be switched on and off as usual also in safe-state mode by briefly pressing the programming button again. The programming LED stops flashing if the programming mode is active.

Deactivating safe-state mode

- Switch off the bus voltage (wait approx. 10 seconds) or carry out the ETS programming procedure.

Master reset

The master reset restores the basic device settings (physical address 15.15.255, firmware remains in place). The device must then be recommissioned with the ETS.

In secure operation, a master reset will deactivate the device security. The device can then be recommissioned with the device certificate.

Performing a master reset

Prerequisite: safe-state mode is activated.

- Press and hold down the programming button for > 5 s.

The programming LED flashes quickly.

- Release the programming button.

The programming LED is illuminated. The device performs a master reset and restarts.

The programming LED goes out after approx. 5 s. The device is ready for operation again.

Restoring the device to factory settings

The device can be reset to the default settings with the Gira ETS Service app. This function uses the firmware included in the device that was active at the time of delivery (delivery state). The device will lose its physical address and configuration by restoring the default settings.

7 Technical data

Ambient temperature	-5 ... +45 °C
Storage/transport temperature	-25 ... +75 °C
Degree of protection	IP20
Protection class	III
Number of channels	
5182 00, 5192 00	2
5184 00, 5194 00	4
5188 00, 5198 00	8
Output voltage	
5182 00, 5184 00, 5188 00	DC 3.3 V SELV
5192 00, 5194 00, 5198 00	DC 5 V SELV
Output current per channel	
5182 00, 5184 00, 5188 00	max. 3.3 mA
5192 00, 5194 00, 5198 00	max. 3.2 mA
LED current (red LED with 1.7 V current voltage)	
5182 00, 5184 00, 5188 00	1.6 mA per output
5192 00, 5194 00, 5198 00	2.2 mA per output
Connection of channels	
5182 00, 5192 00	3-core wiring harness
5184 00, 5194 00	5-core wiring harness
5188 00, 5198 00	2x 5-core wiring harness
Length, wiring harness	
5182 00, 5184 00, 5188 00	25 cm, can be extended to max. 10 m
5192 00, 5194 00, 5198 00	25 cm, can be extended to max. 30 m
Recommended cable	J-Y(St)Y 2×2×0.8
Dimensions (WxHxD)	
5182 00, 5192 00, 5184 00, 5194 00	43.0 x 28.5 x 15.4 mm
5188 00, 5198 00	43.5 x 35.5 x 15.4 mm
KNX medium	TP256
KNX commissioning mode	S mode
Rated voltage	DC 21 ... 32 V SELV
Current consumption, bus	
5182 00	4 ... 7 mA
5184 00	4 ... 9 mA
5188 00	4 ... 12 mA
5192 00	5 ... 10 mA
5194 00	5 ... 12 mA
5198 00	5 ... 18 mA

Connection bus

Device connection terminal

8 Accessories

Remote sensor

Art. no. 1493 00

Leakage sensor

Art. no. 5068 00

Condensation sensor

Art. no. 5069 00

9 Warranty

The warranty is provided by the specialist trade in accordance with statutory requirements. Please submit or send faulty devices postage paid together with a fault description to your responsible salesperson (specialist trade / installation company / electrical specialist trade). They will forward the devices to the Gira Service Center.

Gira
Giersiepen GmbH & Co. KG
Elektro-Installations-
Systeme

Industriegebiet Mermbach
Dahlienstraße
42477 Radevormwald

Postfach 12 20
42461 Radevormwald

Deutschland

Tel +49(0)21 95 - 602-0
Fax +49(0)21 95 - 602-191

www.gira.de
info@gira.de