

Product name: **Push button sensor 2 1-/2-/3-/4fold with controller F-Line**

Design: Flush-mounting type (uP)

Article no.: **2061 ... 1fold**

2062 ... 2fold

2063 ... 3fold

2044 ... 4fold

2064 ... 4fold (2+2)

ETS search path: push button / push button, 4fold / push sensor 2 4fold with controller F-line
 push button / push button, 3fold / push sensor 2 3fold with controller F-line
 push button / push button, 2fold / push sensor 2 2fold with controller F-line
 push button / push button, 1fold / push sensor 2 1fold with controller F-line

Functional description:

The push sensor 2 F-line is plugged onto a flush-mounted bus coupler (cf. wiring diagram). On pressing of a key, the push sensor 2 F-line transmits telegrams depending on the parameters programmed via the KNX / EIB. These may include telegrams for switching or dimming (also single-key dimming) or for blind/shutter control. It is also possible to program value-transmit functions such as dimming value transmitter, light-scene extensions, 2-byte analog value transmitter (temperature or brightness transmitter) or 1-byte universal value transmitter (continuous run between start and target value). The keys or rockers can be independently assigned to the different functions.

The push sensor 2 F-line with controller moreover permits disabling of individual keys or rockers or the complete push sensor. The operation-LED can be switched on or off via an object (in this case, a disabling function is no longer available). On removal of the push sensor 2 F-line from the bus coupler, the device can transmit an alarm message (1 bit or 1 byte).

Layout:

Depending on variant.
e.g.. 4fold (2064 xxx)

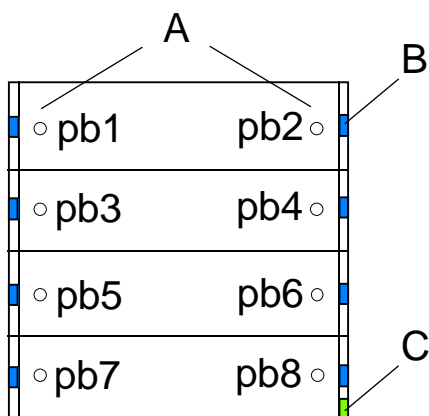

Dimensions:

1-, 2-, 3-, 4fold
(2064 xxx):

width: 70 mm
height: 70 mm
depth: 13 mm
(without PEI)

4fold (2044 xxx):

width: 70 mm
height: 140 mm
depth: 13 mm
(without PEI)

Controls:

A: rockers or buttons with labelling field (depending on project variant)

B: status-LEDs (blue) (depending on project variant)

C: 1 operation-LED (green) (goes out automatically when the status-LED above lights up)

Sensor

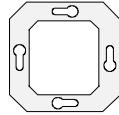

Technical data

Type of protection:	IP 20
Safety class:	III
Mark of approval:	KNX / EIB
Ambient temperature:	-5 °C ... +45 °C
Storage / transport temperature:	-25 °C ... +70 °C (storage above +45 °C reduces the service life)
Mounting position:	any
Minimum distances:	none
Type of fastening:	plug-in on flush-mounted bus coupler (please refer to: "Hardware information")

KNX / EIB supply	
voltage:	21 ... 32 V DC SELV
power consumption:	typically 150 mW
connection:	2 x 5-pole male connector strip

External supply	---
-----------------	-----

Response to mains failures	
bus voltage only:	object values are deleted, LEDs switch off
mains voltage only:	---
bus and mains voltage:	---

Response on return of voltage	
bus voltage only:	no reaction (cf: "Disable object" in software information)
mains voltage only:	---
bus and mains voltage:	---

Wiring:

Terminal connections:

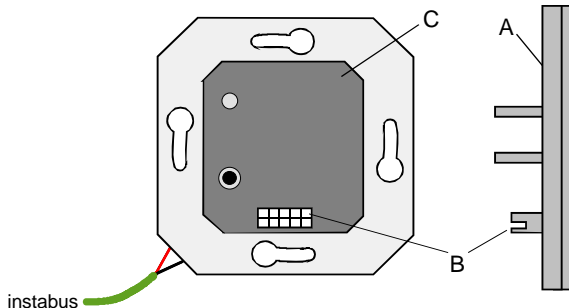

- A: push sensor 2 F-line
- B: user interface
- C: bus coupler



Hardware information

- The push sensor 2 F-line with controller may only be plugged into bus couplers of the "new generation" (cf. bus coupler picture above with round programming button). Plugging the push sensor 2 F-line into older flush-mounted bus couplers results in malfunctions.
- All variants are exclusively plugged onto a flush-mounted BCU. The push sensor 2 4fold F-line (2044 xxx) can only be installed with a double design frame without middle strip.
- The operation-LED (green) goes out automatically when the status-LED above lights up

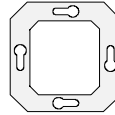

Montage

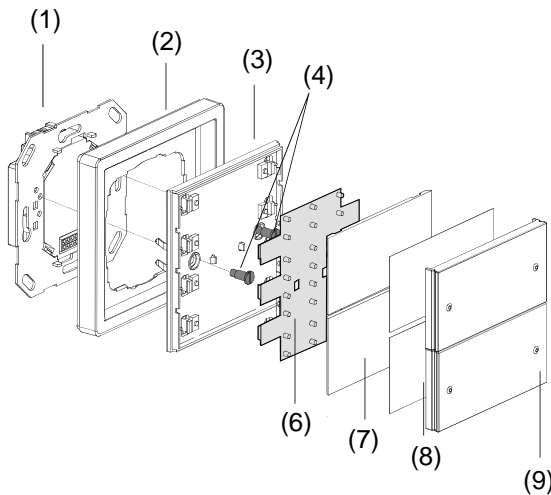

1-, 2-, 3-, 4fold (2064 xxx)

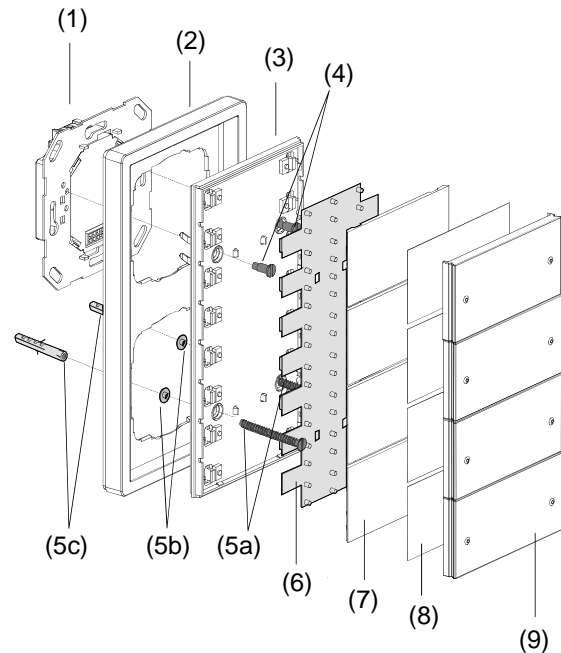

4fold (2044 xxx)

Procedure:

1.) Assembly without anti-theft protection:

Place the cover frame (2) and the user module (3) on a flush-mounted BCU (1).

2.) Assembly with removal protection:

The device is protected against theft by fastening it with screws on the bus coupler insert.

- remove the cover frame (9),
- remove the rocker carrier (7) carefully with a screwdriver or with your fingernail,
- lift off the ESD protection mat (6),
- place the cover frame (2) and the user module (3) on the flush-mounted BCU already in place (1),
- screw the pushbutton sensor to the insert using only the screw set (4, 5a, 5b, 5c) supplied with the device,
- put the ESD protection mat (6) carefully back in place.

Important: proper functioning can only be guaranteed when the ESD protection mat is in place.

Otherwise risk of irreparable damage to the device in operation by electro-static discharge.

- Fit the rocker carrier (7), the inscription foil (8) and the rocker cover (9) by snap-fastening them on the device.

Sensor

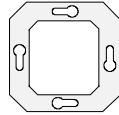

Software description

ETS-search path:
push button / push button, 1fold / push sensor 2 1fold with controller F-line

ETS-symbol:

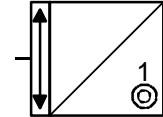

Application: Summarized description:	Name:	Date:	Page:	Version:
multi-function F-line	multi-function F-line 10A701	08.06	5	20619110

ETS-search path:
push button / push button, 2fold / push sensor 2 2fold with controller F-line

ETS-symbol:

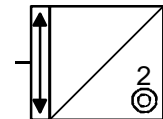

Application: Summarized description:	Name:	Date:	Page:	Version:
multi-function F-line	multi-function F-line 10A801	08.06	5	20629110

ETS-search path:
push button / push button, 3fold / push sensor 2 3fold with controller F-line

ETS-symbol:

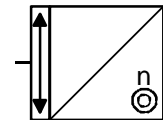

Application: Summarized description:	Name:	Date:	Page:	Version:
multi-function F-line	multi-function F-line 10A901	08.06	5	20639110

ETS-search path:
push button / push button, 4fold / push sensor 2 4fold with controller F-line

ETS-symbol:

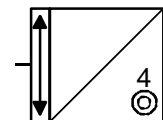

Application: Summarized description:	Name:	Date:	Page:	Version:
multi-function F-line	multi-function F-line 10AA01	08.06	5	20449110

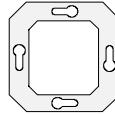

Application:	multi function F-Line 10A701	multi function F-Line 10A901
	multi function F-Line 10A801	multi function F-Line 10AA01

General

- Free assignment of the functions Switching / Pushbutton operation, Dimming, shutter / blind, Value transmitter / Light-scene extension, Analog value transmitter and Universal value transmitter EIS 6 (only with rocker function) to the keys or rockers
- Status indication for each key via blue LED possible (status indication with rocker function via status objects and status or confirm function with key function possible)
- The status-LEDs can be controlled via objects even if "no function" is assigned to keys or rockers
- Automatic shutoff of operation-LED can be parameterized.
- Operation-LED can be switched via object
- Disable object for disabling of individual keys or rockers available (polarity of disable object presettable)
- Alarm message after removal of device from flush-mounted bus coupler can be parameterized (1 bit or 1 byte)

Switching / pushbutton function

- Command to be performed during press or release of key presettable (ON, OFF, TOGGLE, no function)
- Center press with rocker function possible (only if "Command performed during press on rocker = left = TOGGLE, right = TOGGLE ")
- Function of status-LED for key function or status indication for rocker function can be parameterized

Dimming function

- Time between dimming and switching and dim step presettable
- Telegram repetition and transmission of stop telegram possible
- Center press with rocker function possible (only if "Pushbutton function = left = TOGGLE, right = TOGGLE")
- Function of status-LED for key function or status indication for rocker function can be parameterized

Shutter / blind function

- Key function (UP, DOWN) presettable
- Operation sequence parameterizable (STEP – MOVE – STEP or MOVE – STEP)
- Time between shot-time and long-time operation presettable (only with STEP – MOVE – STEP)
- Slat adjusting time (time during which a MOVE command can be terminated by releasing the key) presettable
- Function of status-LED for key function or status indication for rocker function can be parameterized

Value transmitter / light-scene extension function (only with key function)

- Key functions value transmitter EIS 6 (1 byte) or light-scene recall with / without storage function can be parameterized
- Value readjust by long press of key possible with value transmitter EIS 6
- Function of status-LED can be parameterized

Analog value transmitter function (only with key function)

- Key functions brightness value transmitter EIS 5, temperature value transmitter EIS 5 and value transmitter EIS 10 can be parameterized
- Value readjust by long press of key possible
- Function of status-LED can be parameterized

Universal value transmitter function EIS 6 (only with rocker function)

- Start-, support- and target value can be parameterized
- The support value divides the value range into two partial ranges. Time base and time factor presettable for one step of the partial ranges
- Number of steps in partial ranges selectable
- Sense of action and response to key-press (start / stop) can be parameterized

Sensor

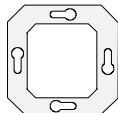

Object	Object description
☐ 0 - 7 Status:	1 bit object for control of the status-LED of a key or rocker
☐ 0 - 7 Switching:	1 bit object for transmission of switching telegrams (ON, OFF)
☐ 8 - 15 Dimming:	4 bit object for relative change of brightness between 0 and 100 %
☐ 0 - 7 Short-time operation:	1 bit object for short-time operation of blind/shutter
☐ 8 - 15 Long-time operation:	1 bit object for long-time operation of blind/shutter
☐ 8 - 15 Light-scene extension:	1 byte object for recall or storage of light-scenes (1 - 64)
☐ 8 - 15 Value EIS 6:	1 byte object for transmission of e.g. dimming value telegrams (0 - 255)
☐ 8 / 10 / 12 / 14 Universal value transmitter EIS 6	1 byte object for transmission of value telegrams (0 – 255) of universal value transmitter
☐ 8 - 15 Temp. value EIS 5:	2 byte object for the adjustment of a firm temperature value (0 - 40 °C)
☐ 8 - 15 Brightn. value EIS 5:	2 byte object for the adjustment of a firm brightness value (0 - 1500 lux)
☐ 8 - 15 Value EIS 10:	2 byte object for the transmission of value telegrams (0 - 65535)
☐ 17 Switching:	1 bit object for the switching of the operation-LED
☐ 17 Disabling:	1 bit object for disabling of keys or rockers of the push sensor
☐ 16 Switching:	1 bit object for the transmission of an alarm message
☐ 16 Value:	1 byte object for the transmission of an alarm message

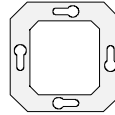

Sensor

Number of addresses (max):	25	dynamic table handling	Yes <input checked="" type="checkbox"/>	No <input type="checkbox"/>
Number of assignments (max):	28	maximum number of assignments	53	
Communication objects:	max. 18			

The following objects are only applicable if "rocker actuation = key function":
Function: no function (for all keys *)

Object	Function	Name	DPT_ID	Type	Flag
<input type="checkbox"/> 0-7	Status	Key 1 – Key 8 *	1.001	1 bit	C, W

Function: Switch / pushbutton function (for all keys *)

Object	Function	Name	DPT_ID	Type	Flag
<input type="checkbox"/> 0-7	Switch / pushbutton	Key 1 – Key 8 *	1.001	1 bit	C, W, T

Function: Dimming (for all keys *)

Object	Function	Name	DPT_ID	Type	Flag
<input type="checkbox"/> 0-7	Switching	Key 1 – Key 8 *	1.001	1 bit	C, W, T
<input type="checkbox"/> 8-15	Dimming	Key 1 – Key 8 *	3.007	4 bit	C, W

Function: Blind/shutter (for all keys *)

Object	Function	Name	DPT_ID	Type	Flag
<input type="checkbox"/> 0-7	Short-time operation	Key 1 – Key 8 *	1.007	1 bit	C, W
<input type="checkbox"/> 8-15	Long-time operation	Key 1 – Key 8 *	1.008	1 bit	C, W

Function: Value transmitter (pushbutton function: light-scene recall with/without storage function for all keys*)

Object	Function	Name	DPT_ID	Type	Flag
<input type="checkbox"/> 8-15	Light-scene extension	Key 1 – Key 8 *	18.001	1 byte	C, W

Function: Value transmitter (pushbutton function: value transmitter EIS 6 for all keys *)

Object	Function	Name	DPT_ID	Type	Flag
<input type="checkbox"/> 8-15	Value EIS 6	Key 1 – Key 8 *	5.001	1 byte	C, W

Function: Analog value transmitter (pushbutton function: temperature value transmitter EIS 5 for all keys *)

Object	Function	Name	DPT_ID	Type	Flag
<input type="checkbox"/> 8-15	Temperature value EIS 5	Key 1 – Key 8 *	9.001	2 bytes	C, W

Function: Analog value transmitter (pushbutton function: brightness value transmitter EIS 5 for all keys *)

Object	Function	Name	DPT_ID	Type	Flag
<input type="checkbox"/> 8-15	Brightness value EIS 5	Key 1 – Key 8 *	9.004	2 bytes	C, W

Function: Analog value transmitter (pushbutton function: value transmitter EIS 10 for all keys *)

Object	Function	Name	DPT_ID	Type	Flag
<input type="checkbox"/> 8-15	Value EIS 10	Key 1 – Key 8 *	7.001	2 bytes	C, W

* The number of keys or objects depends on the variant projected.

The functions: switching / pushbutton, dimming, blind/shutter, light-scene extension and value transmitter can be selected for each key. The names of the communication objects and the object table (dynamic object structure) change accordingly. Key or rocker functions can also be combined.

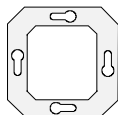

The following objects are only applicable if "rocker actuation = rocker function":

Function: No function (for all rockers *)

Object	Function	Name	DPT_ID	Type	Flag
☐← 1 / 3 / 5 / 7	Status	Rocker 1 – Rocker 4 *	1.001	1 bit	C, W

Function: Schalten (for all rockers *)

Object	Function	Name	DPT_ID	Type	Flag
☐← 0 / 2 / 4 / 6	Switching	Rocker 1 – Rocker 4 *	1.001	1 bit	C, W, T
☐← 1 / 3 / 5 / 7	Status	Rocker 1 – Rocker 4 *	1.001	1 bit	C, W

Function: Dimming (for all rockers *)

Object	Function	Name	DPT_ID	Type	Flag
☐← 0 / 2 / 4 / 6	Switching	Rocker 1 – Rocker 4 *	1.001	1 bit	C, W, T
☐← 1 / 3 / 5 / 7	Status	Rocker 1 – Rocker 4 *	1.001	1 bit	C, W
☐ 8 / 10 / 12 / 14	Dimming	Rocker 1 – Rocker 4 *	3.007	4 bit	C, T

Function: Blind/shutter (for all rockers *)

Object	Function	Name	DPT_ID	Type	Flag
☐ 0 / 2 / 4 / 6	Short-time operation	Rocker 1 – Rocker 4 *	1.007	1 bit	C, T
☐← 1 / 3 / 5 / 7	Status	Rocker 1 – Rocker 4 *	1.001	1 bit	C, W
☐ 8 / 10 / 12 / 14	Long-time operation	Rocker 1 – Rocker 4 *	1.008	1 bit	C, T

Function: Universal value transmitter EIS 6 (for all rockers *)

Object	Function	Name	DPT_ID	Typ	Flag
☐← 1 / 3 / 5 / 7	Status	Rocker 1 – Rocker 4 *	1.001	1 bit	C, W
☐ 8 / 10 / 12 / 14	Universal value transmitter EIS 6	Rocker 1 – Rocker 4 *	5.001	1 byte	C, T

The following objects are available for the disabling function, the operation-LED or the alarm function:

Function: Only if operation-LED = "ON", "OFF" or "Automatic shutoff" and disable behaviour = "All rockers behaving like rockers 1...4" *, "Individual rockers disabled" or "Complete push sensor disabled"

Object	Function	Name	DPT_ID	Typ	Flag
☐← 17	Disable	Keys / Rockers	1.003	1 bit	C, W

Function: Only if labelling field illumination = "Switching via object"

Object	Function	Name	DPT_ID	Typ	Flag
☐← 17	Switching	Operation-LED	1.001	1 Bit	C, W

Function: Alarm message "data format 1 bit"

Object	Function	Name	DPT_ID	Typ	Flag
☐ 16	Switching	Alarm message	1.001	1 Bit	C, T

Function: Alarm message " data format 1 byte"

Object	Function	Name	DPT_ID	Typ	Flag
☐ 16	Value	Alarm message	5.001	1 byte	C, T

* The number of rockers or objects depends on the projected variant.
The functions: switching / pushbutton, dimming, blind/shutter, light-scene extension and value transmitter can be selected for each key. The names of the communication objects and the object table (dynamic object structure) change accordingly. Key or rocker functions can also be combined.

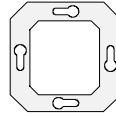

Functional description

Value transmitter EIS 6 / analog value transmitter: readjustment by long key-press

Value transmitters (value transmitter EIS 6 or analog value transmitter) can be parameterized so that the value to be transmitted can be readjusted by means of a long press on the key (> 5 s). In this case, the programmed value is reduced by the parameterized step and then transmitted. When the key is released, the value last transmitted remains in memory. The next long press on the key changes the direction in which the value is changed.

The status-LED of the key pressed and that of the opposite key are flashing (ca. 3 Hz) when the value is changed (see below). If several variants are available, no further key may be pressed as long as value adjustment is in progress.

Examples for value transmitter EIS 6:

1.) Function of status-LED always ON
Dimming value (0...255) 17
Step rate (1...10) 5

⇒ The status LED is on. During value adjustment, it starts flashing as long as value adjustment is in progress.

2.) Function of status-LED key-press confirmation indicator
ON-duration of confirm indicator 3 s
Dimming value (0...255) 17
Step rate (1...10) 5

⇒ The status-LED is lit up for the parameterized time when a key is pressed. During value adjustment, it starts flashing as long as value adjustment is in progress.

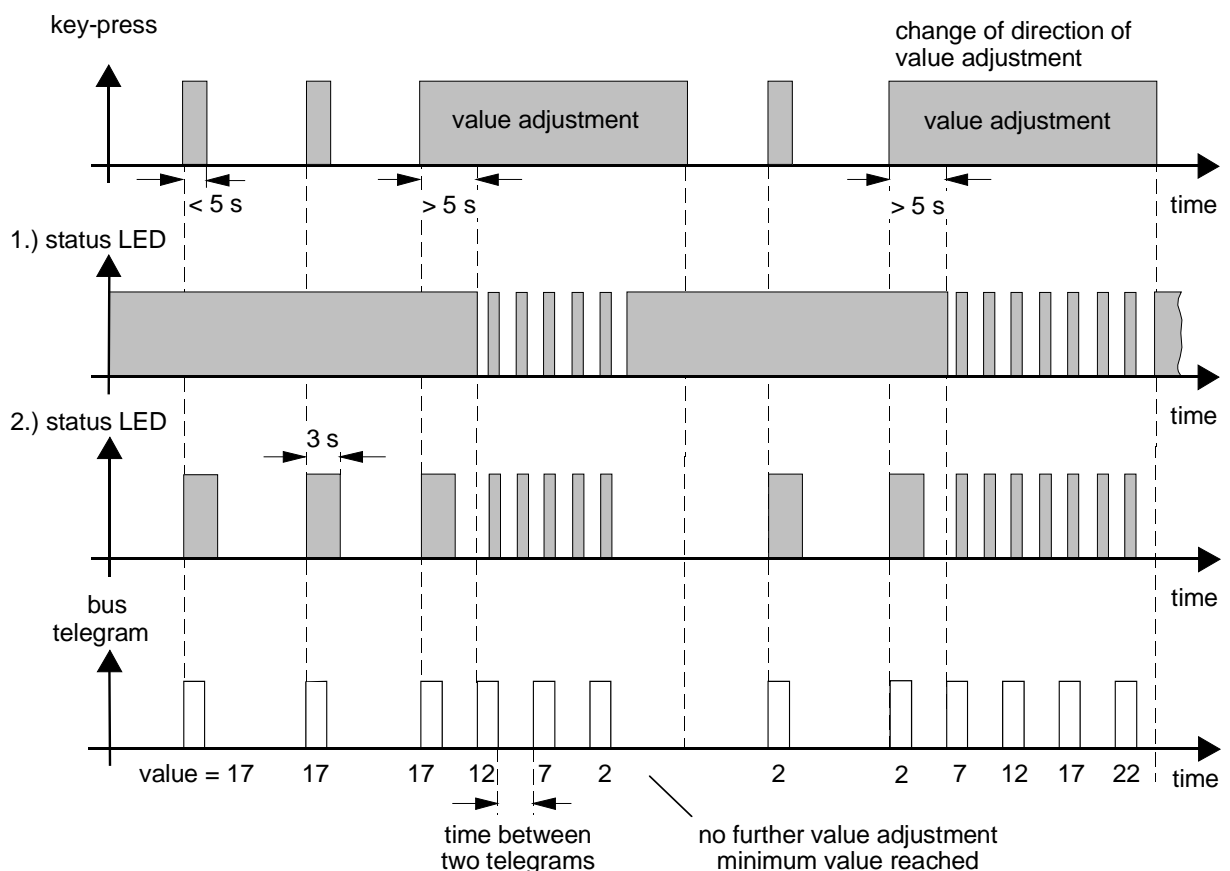

Sensor

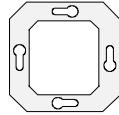

Important:

It may occur that - during a value change - value "0" is never reached depending on the parameterized step rate (cf. value adjustment example above). This is to ensure that - in the event of a new value adjustment - the value originally parameterized with the ETS can again be exactly reached.

Light-scene extension with / without storage function:

In the event of a parametrization as light-scene extension without storage function, it is possible to call up a light-scene. When the key is pressed, the parameterized light-scene number is transmitted. The status-LED of the key pressed is lit up for the parameterized time if programmed as key-press confirmation indicator.

In the event of a parametrization as light-scene extension with storage function, it is possible to generate a storage telegram depending on the light-scene to be transmitted. A long key-press > 5 s transmits the corresponding storage telegram. In this case, the status-LED of the key pressed and that of the key opposite will flash (ca. 3 Hz) (see below). No other key may be pressed as long as storage is in progress. A short press on the key < 1 s transmits the parameterized light-scene number (without storage telegram). The status-LED of the key pressed is lit up for the parameterized time if programmed as key-press confirmation indicator. If the key is pressed longer than 1 s, but shorter than 5 s, no telegram will be triggered. In this case, the LED is not switched on if programmed as key-press confirmation indicator.

Examples for light-scene extension with storage function:

1.) Function of status-LED always ON

⇒ The status LED is always on. During storage, it starts flashing for ca. 3 s.

2.) Function of status-LED key-press confirmation indicator

ON-duration of key-press confirmation indicator

0,75 s

⇒ The status-LED is lit up for the parameterized time when a key is pressed. During storage, it starts flashing for ca. 3 s.

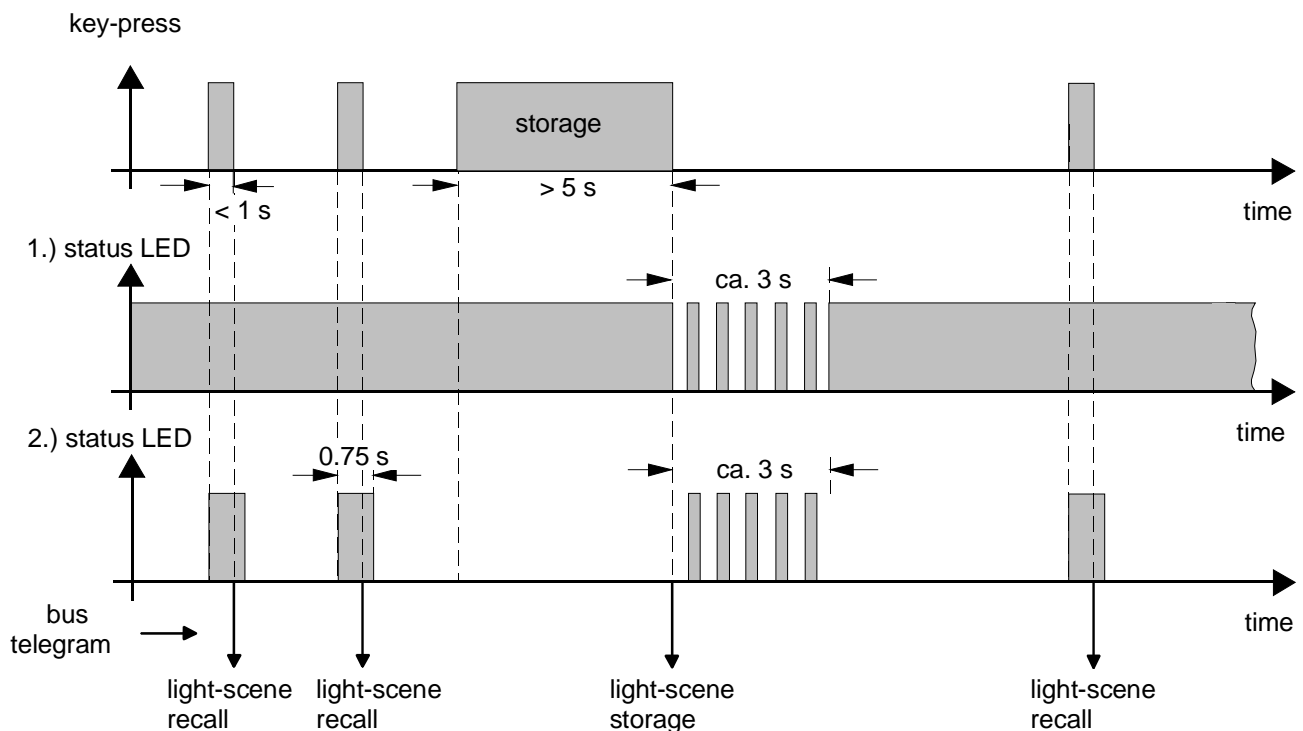

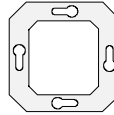

Universal value transmitter EIS 6

The range of values of the universal value transmitter EIS 6 encompasses 8 bits. For this function, a start, a target and a support value in between can be parameterized. The support value divides the range of values between start and target value into two partial ranges. The partial ranges, in turn, are subdivided into a given number of steps which is the same for both partial ranges. For each step of a partial range, a time can be parameterized which predefines after which the next step is to be reached or transmitted. The time is composed of a common base for both partial ranges and of an individual factor for each range.

Example showing the division of the value range and the number of steps for universal value transmitter EIS 6:

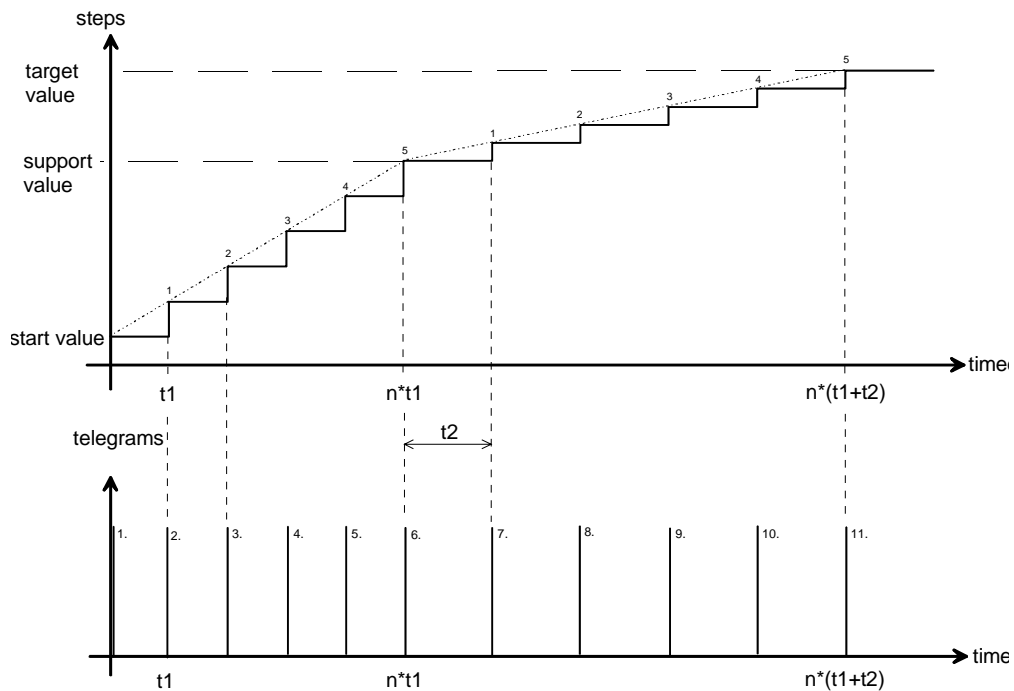

n : number of steps

t_1 : time for a step in partial range 1 consisting of time base and time factor 1

t_2 : time for a step in partial range 2 consisting of time base and time factor 2

Depending on the parameter "Response to key-press", either the whole range of values can be scanned as long as the respective key is pressed ("Scan as long key is pressed"), or the scan can be started with the first press of the key and stopped with the second press ("Scan start or stop"). In the latter case, it is possible to execute in addition to the scan of the universal value transmitters EIS 6 another rocker or pushbutton function or to have all three universal value transmitters EIS 6 of the individual rockers run at the same time. The scan direction is determined by the "Direction of action" parameter, i.e. it can be defined whether the start or the target value is to be transmitted first on actuation of the left or the right key of a rocker.

Important:

It must be ensured that the start value < support value < target value. If these values are not parameterized as described, the universal value transmitter EIS 6 performs no actions.

In the worst case, the actual time of a step may slightly deviate from the parameterized time. This effect may be present especially in the event of high bus loading. Besides the time deviation, a deviation in the step values is also possible. Since the function is an 8-bit value transmitter without fractional digits in its telegrams, the step division can only be in integer steps, so that slight deviations in the transmitted values have to be taken into account, too. It is also possible that the number of steps has been selected greater than the partial range itself. In this case, the same values may be transmitted several times in succession.

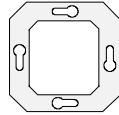

Parameters		
Description:	Values:	Remarks:
 General		
ON-time of key-press confirm indicator	0.75 s 2.25 s 3 s	Defines the ON-time of the status-LED as key-press confirm indicator.
Operation LED	OFF ON automatic shutoff switching via object (object = 1 : ON) switching via object (object = 1 : OFF)	<p>Defines the function of the operation LED.</p> <p>The operation LED is always off.</p> <p>The operation LED is always on.</p> <p>The operation LED is lit up after a key-press and shut off automatically after the parametrized time.</p> <p>The operation LED can be switched via an object. If a "1" is written into the object, the operation LED is on (and vice versa).</p> <p>The operation-LED can be switched via an object. If a "0" is written into the object, the operation-LED is on (and vice versa).</p> <p>Important: The operation-LED goes out automatically when the status-LED above lights up. Lighting up of the blue status-LED is parameter-dependent.</p>
Automatic shutoff of operation -LED Base	0.5 s 1 s 2.5 s 5 s	<p>Defines the timebase which fixes the time after a key-press during which the operation-LED is on until automatic shutoff.</p> <p>Time = Base · Factor</p>
Automatic shutoff of operation-LED Factor (1...255)	1 to 255, 10	<p>Defines the time factor which fixes the time after a key-press during which the operation-LED is on until automatic shutoff.</p> <p>Time = Base · Factor</p> <p>Preset value: 10 · 1 = 10 s</p>

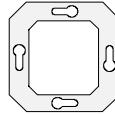

Alarm function	disabled enabled	On removal of the push sensor 2 F-line from the flush-mounted bus coupler, an alarm message can be sent over the bus. This parameter defines whether the alarm function is enabled or disabled.
Data format	1 bit 1 byte	Defines the data format of the alarm message.
1 bit value	OFF ON	Defines the value of the switching telegram transmitted in the event of an alarm message. Only with data format = "1 bit".
1 byte value (0...255)	0 to 255, 255	Defines the value of the value telegram transmitted in the event of an alarm message. Only with data format = "1 byte".
 Disabling behaviour		
Polarity of disable object	not inverted (disable = 1; enable = 0) inverted (disable = 0; enable = 1)	Defines the polarity of the disable object.
Disabling behaviour	push sensor not disabled behaviour of all rockers like rocker 1...n * individual rockers disabled complete push sensor disabled	This parameter defines the behaviour of the push sensor 2 F-line when the disable function is active. The disable function is deactivated. When the disable function is active, all rockers * of the push sensor 2 F-line des behave like the parametrized one. When the disable function is active, individual rockers of the push sensor 2 F-line can be disabled. When the disable function is active, the complete push sensor is disabled. *: number depending on projected variant
Behaviour like	rocker 1 * rocker 2 * rocker 3 * rocker 4 *	When the disable function is active, all rockers * of the push sensor 2 F-line behave like the parametrized one. Only if disable behaviour = "Behaviour of all rockers like rocker 1...4". *: number depending on projected variant

Sensor

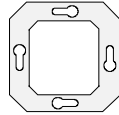

Rocker X disabled ? X = 1 to n * *: number depending on projected variant	YES NO	Defines whether rocker X (X = 1 to n *) is disabled when the disable function is active, i.e. a press on the keys (left and right) of this rocker is without function. Only if disable behaviour = "Individual rockers disabled". *: number depending on projected variant
Actuation		
Rocker X (X = 1 to n *) Rocker or key function *: number depending on projected variant	keys rockers without function	Each rocker of the Push sensor 2 F-line can be programmed for two key functions or for one rocker function. Rocker X (X = 1 to n *) is programmed for two independent key functions. Rocker X (X = 1 to n *) is programmed for one rocker function. Rocker X (X = 1 to n *) has no function, i.e. a press on the key (left or right) has no effect and the status-LEDs of this rocker cannot be activated. *: number depending on projected variant
Key 1		
Function of key 1	no function switch / pushbutton dimmer shutter / blind value transmitter / light-scene extension analog value transmitter	Defines the function of key 1.
Function of key 1 = "no function"		
Function of status-LED	always OFF always ON status indication inverted status indication	If function of key 1 = "No function", only the status-LED of the key can be activated via the corresponding object. A press on the key has no effect. The status-LED is always off. The status-LED is always on. The status-LED indicates the object status. The status-LED indicates the inverted object status.

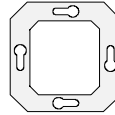

Function of key 1 = "switch / pushbutton"		
Function of status-LED	always OFF always ON status indication inverted status indication key-press confirm indication	Defines the function of the status-LED. The status-LED is always off. The status-LED is always on. The status-LED indicates the object status. The status-LED indicates the inverted object status. After a key-press, the status-LED lights up for the parameterized time.
Command when key is pressed	no function ON OFF TOGGLE	Defines the command transmitted on pressing the key.
Command when key is released	no function ON OFF TOGGLE	Defines the command transmitted on releasing the key.
Function of key 1 = "dimmer"		
Function of status-LED	always OFF always ON status indication inverted status indication key-press confirm indication	Defines the function of the status-LED. The status-LED is always off. The status-LED is always on. The status-LED indicates the object status. The status-LED indicates the inverted object status. After a key-press, the status-LED lights up for the parameterized time.
Send stop telegram ?	YES NO	On release of the key, a stop telegram is either transmitted or not.

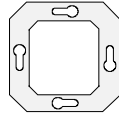

Pushbutton function	<p>darker (OFF)</p> <p>brighter (ON)</p> <p>brighter / darker (TOGGLE)</p>	<p>Defines the response to a key-press.</p> <p>A short press triggers an OFF telegram, whereas a long press triggers a dimming telegram (darker).</p> <p>A short press triggers an ON telegram, whereas a long press triggers a dimming telegram (brighter).</p> <p>The internally stored switching state is toggled when the key is pressed briefly. If the the stored state is an ON (OFF) state, an OFF (ON) telegram is sent. After a long key-press, a "darker" telegram is sent after a "brighter" telegram and vice versa.</p>
Increase brightness by	<p>100 % 6 %</p> <p>50 % 3 %</p> <p>25 % 1.5 %</p> <p>12.5 %</p>	<p>Defines the maximum dimming step of a dimming telegram. A dimming telegram can increase the brightness by a maximum of X %.</p> <p>This parameter is dependent on the preset key function.</p>
Reduce brightness by	<p>100 % 6 %</p> <p>50 % 3 %</p> <p>25 % 1.5 %</p> <p>12.5 %</p>	<p>Defines the maximum dimming step of a dimming telegram. A dimming telegram can reduce the brightness by a maximum of X %.</p> <p>This parameter is dependent on the preset key function.</p>
Time between switching and dimming Base	<p>130 ms</p> <p>260 ms</p> <p>520 ms</p> <p>1 s</p>	<p>Time after which the function assigned to a long key-press is executed (dimming).</p> <p>Time = Base · Factor</p>
Time between switching and dimming Factor (1...255)	<p>1 to 255, 3</p>	<p>Time after which the function assigned to a long key-press is executed (dimming).</p> <p>Time = Base · Factor</p> <p>Preset value: 130 ms · 3 = 390 ms</p>
Repeat telegram ?	<p>YES</p> <p>NO</p>	<p>Cyclical repetition of dimming telegram while key is pressed.</p>
Time between two telegrams	<p>200 ms 750 ms</p> <p>300 ms 1 s</p> <p>400 ms 1,5 s</p> <p>500 ms 2 s</p>	<p>Time between two telegrams with telegram repetition active.</p> <p>A new dimming telegram is sent when this time has elapsed.</p> <p>Only if "repeat telegram ?" = "YES".</p>

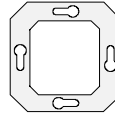

Function of key 1 = " shutter / blind"		
Function of status-LED	<p>always OFF</p> <p>always ON</p> <p>key-press confirm indication</p>	<p>Defines the function of the status-LED.</p> <p>The status-LED is always off.</p> <p>The status-LED is always on.</p> <p>The status-LED lights up during the parameterized time when a key is pressed.</p>
Operational sequence (Telegram sequence)	<p>Step – Move - Step</p> <p>Move - Step</p>	<p>Defines the telegram sequence after a key-press.</p> <p>Step – Move - Step:</p> <p>Pressing the key transmits a STEP command and time T1 (time between short-time and long-time operation) is started. If the key is released within T1, no further telegram will be transmitted. This STEP command serves the purpose of stopping a continuous run in progress.</p> <p>If the key is held depressed for a time longer than T1, the sensor transmits automatically a MOVE command after T1 has elapsed and time T2 (slat adjustment time) is started. If the key is then released again within T2, a STEP command is transmitted. This function is used for slat adjustment. T2 should correspond to the time needed for a slat rotation by 180°.</p> <p>Move - Step:</p> <p>When the key is pressed, a MOVE command is transmitted and time T1 (slat adjustment time) is started. If the key is then released again within T1, a STEP command is transmitted. This function is used for slat adjustment. T1 should correspond to the time needed for a slat rotation by 180°.</p>

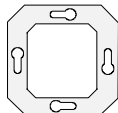

Key function	UP DOWN	A short press triggers a STEP telegram (UP), whereas a long press triggers a MOVE telegram (UP). A short press triggers a STEP telegram (DOWN), whereas a long press triggers a MOVE telegram (DOWN).
Slat adjustment time Base	8 ms 130 ms 2.1 s 33 s	Time during which MOVE telegram for slat adjustment can be ended by releasing the key. Time = Base · Factor
Slat adjustment time Factor (0...255)	0 to 255, 20	Time during which MOVE telegram for slat adjustment can be ended by releasing the key. Time = Base · Factor Preset value: 130 ms · 20 = 2.6 s
Time between short-time and long-time operation Base	8 ms 130 ms 2.1 s 33 s	Time after which the function assigned to a long key-press is executed. Only with operational sequence = "STEP - MOVE - STEP". Time = Base · Factor
Time between short-time and long-time operation Factor (0...255)	0 to 255, 46	Time after which the function assigned to a long key-press is executed. Only with operational sequence = "STEP - MOVE - STEP". Time = Base · Factor Preset value: 8 ms · 46 = 368 ms
Function of key 1 = "value transmitter / light-scene extension"		
Function of status -LED	always OFF always ON key-press confirm indication	Defines the function of the status-LED. The status-LED is always off. The status-LED is always on. The status-LED lights up during the parameterized time when a key is pressed.
Function as	light-scene recall without storage function light-scene recall with storage function value transmitter EIS 6	Defines the function to be executed.
Light-scene number (1...128)	1 to 128, 1	Defines the light-scene number to be transmitted if "function as" = "Light-scene recall with / without storage function".
Value (0...255)	0 to 255, 255	Defines the value to be transmitted if "function as" = "Value transmitter EIS 6".

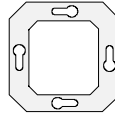

Value adjustment	enabled disabled	If the key is held depressed for at least 5 s, the actual value is cyclically reduced by the parameterized step (see below) and transmitted. After releasing the key, the value last transmitted remains stored. This parameter defines whether value adjustment is possible or not. Only if "Function as" = "Value transmitter EIS 6".
Time between two telegrams	0.5 s; 1 s ; 1.5 s; 2 s	Time between two cyclical telegrams after long key-press. Only if "Function as" = "Value transmitter EIS 6".
Steps (1...10)	1 to 10, 10	Steps by which the set value is being reduced with a long press on the key. Only if "Function as" = "Value transmitter EIS 6".
Function of key 1 = "analog value transmitter"		
Function of status LED	always OFF always ON key-press confirm indication	Defines the function of the status -LED. The status-LED is always off. The status-LED is always on. The status-LED lights up during the parameterized time when a key is pressed.
Function as	brightness value transmitter EIS 5 temperature value transmitter EIS 5 value transmitter EIS 10	Defines the function to be executed.
Brightness value (0...1500 lux)	0 to 1500 lux in 50 lux steps, ca. 300 lux	Sets the brightness value to be transmitted. Only if "Function as" = "Brightness value transmitter EIS 5"
Temperature value (0...40 °C)	0 to 40 °C in 1 °C steps, 20 °C	Sets the temperature value to be transmitted. Only if "Function as" = "Temperature value transmitter EIS 5"
Value (0...65535)	0 bis 65535, 0	Sets the EIS 10 value to be transmitted. Only if "Function as" = "Value transmitter EIS 10"
Value adjustment	enabled disabled	If the key is held depressed for at least 5 s, the actual value is cyclically reduced by the parameterized step (see below) and transmitted. After releasing the key, the value last transmitted remains stored. This parameter defines whether value adjustment is possible or not.

Sensor

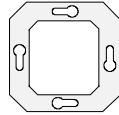

Time between two telegrams	0.5 s; 1 s ; 1.5 s; 2 s	Time between two cyclical telegrams after long key-press.
Step	Temperature value transmitter EIS 5: 1 °C Brightness value transmitter EIS 5: 50 lux Value transmitter EIS 10: 1 75 2 100 5 200 10 500 20 750 50 1000	Step by which the set value is reduced after a long press on the key.
Key 2 see key 1!		
Key 3 see key 1! (depending on projected variant)		
Key 4 see key 1! (depending on projected variant)		
Key 5 see key 1! (depending on projected variant)		
Key 6 see key 1! (depending on projected variant)		
Key 7 see key 1! (depending on projected variant)		
Key 8 see key 1! (depending on projected variant)		
Rocker 1		
Function of rocker 1	no function switch dimmer shutter / blind universal value transmitter EIS 6	Defines the function of rocker 1.
Function of rocker 1 = "no function"		
If function of rocker 1 = "No function", only the status-LED of the rocker can be activated via the corresponding status object. A press on the rocker or key has no effect. No further parameters		
Function of rocker 1 = "switch"		
Command on press of rocker	left = ---, right = --- left = ON, right = OFF left = OFF, right = ON left = TOGGLE, right = TOGGLE	Defines the command transmitted during a press on the key.
Permit center press ?	YES NO	Defines whether a center press on the rocker is permitted (left and right key pressed at the same time). Only if "Command on press of rocker = left = TOGGLE, right = TOGGLE"
Function of rocker 1 = "dimmer"		
Send stop telegram ?	YES NO	On releasing one of the keys (left or right) a stop telegram is sent or not.

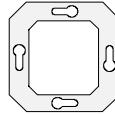

Key function	<p>Left = brighter (ON), right = darker (OFF)</p> <p>Left = darker (OFF), right = brighter (ON)</p> <p>left = TOGGLE, right = TOGGLE</p>	<p>Defines the response when a key of the rocker is pressed.</p> <p>A short key-press (left key) transmits an ON telegram, a long key-press (left key) transmits a dimming telegram (brighter). A short key-press (right key) transmits an OFF telegram, a long key-press (right key) transmits a dimming telegram (darker).</p> <p>A short key-press (left key) transmits an OFF telegram, a long key-press (left key) transmits a dimming telegram (darker). A short key-press (right key) transmits an ON telegram, a long key-press (right key) transmits a dimming telegram (brighter).</p> <p>The internally stored switching state is toggled with a short key-press. If the stored state is ON (OFF), then an OFF (ON) telegram is sent. After a long key-press, a "darker" telegram is transmitted after a "brighter" telegram and vice versa.</p>
Permit center press ?	<p>YES</p> <p>NO</p>	<p>Defines whether a center press on the rocker is permitted (left and right key pressed at the same time). Only if key function = "left = TOGGLE, right = TOGGLE"</p>
Increase brightness by	<p>100 % 6 %</p> <p>50 % 3 %</p> <p>25 % 1.5 %</p> <p>12.5 %</p>	<p>Defines the maximum step of a dimming telegram. With a dimming telegram, the brightness can be increased by a maximum of X %.</p>
Reduce brightness by	<p>100 % 6 %</p> <p>50 % 3 %</p> <p>25 % 1.5 %</p> <p>12.5 %</p>	<p>Defines the maximum step of a dimming telegram. With a dimming telegram, the brightness can be reduced by a maximum of X %.</p>
Time between switching and dimming Base	<p>130 ms</p> <p>260 ms</p> <p>520 ms</p> <p>1 s</p>	<p>Time after which the function assigned to a long key-press (dimming) is executed.</p> <p>Time = Base · Factor</p>
Time between switching and dimming Factor (1...255)	<p>1 bis 255, 3</p>	<p>Time after which the function assigned to a long key-press (dimming) is executed.</p> <p>Time = Base · Factor</p> <p>Preset value: 130 ms · 3 = 390 ms</p>
Repeat telegram ?	<p>YES</p> <p>NO</p>	<p>Cyclical repetition of dimming telegram during the key-press.</p>

Sensor

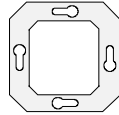

Time between two telegrams	<table border="0"> <tr> <td>200 ms</td> <td>750 ms</td> </tr> <tr> <td>300 ms</td> <td>1 s</td> </tr> <tr> <td>400 ms</td> <td>1.5 s</td> </tr> <tr> <td>500 ms</td> <td>2 s</td> </tr> </table>	200 ms	750 ms	300 ms	1 s	400 ms	1.5 s	500 ms	2 s	Time between two telegrams when telegram repetition is active. A new dimming telegram is sent when this time has elapsed. Only if "Repeat telegram ?" = "YES".
200 ms	750 ms									
300 ms	1 s									
400 ms	1.5 s									
500 ms	2 s									
Function of rocker 1 = "shutter / blind"										
Operational sequence (telegram sequence)	<p>Step – Move - Step Move - Step</p>	<p>Defines the telegram sequence after a key-press.</p> <p>Step – Move - Step:</p> <p>Pressing the key transmits a STEP command and time T1 (time between short-time and long-time operation) is started. If the key is released within T1, no further telegram will be transmitted. This STEP command serves the purpose of stopping a continuous run in progress.</p> <p>If the key is held depressed for a time longer than T1, the sensor transmits automatically a MOVE command after T1 has elapsed and time T2 (slat adjustment time) is started. If the key is then released again within T2, a STEP command is transmitted. This function is used for slat adjustment. T2 should correspond to the time needed for a slat rotation by 180°.</p> <p>Move - Step:</p> <p>When the key is pressed, a MOVE command is transmitted and time T1 (slat adjustment time) is started. If the key is then released again within T1, a STEP command is transmitted. This function is used for slat adjustment. T1 should correspond to the time needed for a slat rotation by 180°.</p>								

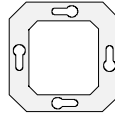

Key function	left = UP, right = DOWN left = DOWN, right = UP	<p>A short key-press (left key) transmits a STEP telegram (UP), a long key-press (left key) transmits a MOVE telegram (UP). A short key-press (right key) transmits a STEP telegram (DOWN), a long key-press (right key) transmits a MOVE telegram (DOWN).</p> <p>A short key-press (left key) transmits a STEP telegram (DOWN), a long key-press (left key) transmits a MOVE telegram (DOWN). A short key-press (right key) transmits a STEP telegram (UP), a long key-press (right key) transmits a MOVE telegram (UP).</p>
Slat adjustment time Base	8 ms 130 ms 2.1 s 33 s	Time during which MOVE telegram for slat adjustment can be ended by releasing the key Time = Base · Factor
Slat adjustment time Factor (0...255)	0 to 255, 20	Time during which MOVE telegram for slat adjustment can be ended by releasing the key. Time = Base · Factor Preset value: 130 ms · 20 = 2.6 s
Time between short-time and long-time operation Base	8 ms 130 ms 2.1 s 33 s	Time after which the function assigned to a long key-press is executed. Only with operational sequence = "STEP - MOVE - STEP". Time = Base · Factor
Zeit zwischen Kurz- und Langzeitbetrieb Faktor (0...255)	0 bis 255, 46	Time after which the function assigned to a long key-press is executed. Only with operational sequence = "STEP - MOVE - STEP". Time = Base · Factor Preset value: 8 ms · 46 = 368 ms
Function of rocker 1 = "universal value transmitter EIS 6"		
Sense of action left key (right key with opposite sense)	run from start to target value run from target to start value	This parameter defines the direction of scan, i.e. it can be defined whether the start or the target value is transmitted first when the left key is pressed. The right key has always the opposite effect.

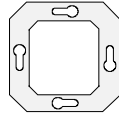

Response to key-press	<p>scan as long as key is depressed</p> <p>start or stop scan</p>	<p>Defines how the universal value transmitter EIS 6 can be started or stopped.</p> <p>As long as the left or right key is held depressed, the universal transmitter EIS 6 transmits values to the bus. When both partial ranges have been scanned and if the key is then still depressed, the transmission of values is stopped.</p> <p>When the left or right key is pressed, the universal value transmitter EIS 6 transmits values to the bus even if the key is released. Only after the next press of a key will the universal value transmitter EIS 6 be stopped. After both partial ranges have been scanned, the transmission of values is stopped. In this case, the scan restarts after another key-press.</p>
Number of steps (1...15) Partial ranges 1 and 2	1 to 15, 10	Defines the number of steps in partial ranges 1 and 2.
Timebase Partial ranges 1 and 2	<p>approx. 0.6 s approx. 3.2 s</p> <p>approx. 1.2 s approx. 3.8 s</p> <p>approx. 1.9 s approx. 4.5 s</p> <p>approx. 2.4 s</p>	<p>For each step in the partial ranges, a time can be parameterized. This time determines when the next step is reached or transmitted. Defines the common timebase for both partial ranges.</p> <p>Time = Base · Factor</p>
Time factor (1...255) Time for one step in partial range 1	1 to 255, 10	<p>For each step in the partial ranges, a time can be parameterized. This time determines when the next step is reached or transmitted. Defines the time factor for partial range 1 fest.</p> <p>Time = Base · Factor</p> <p>Preset value: 10 · 0.6 s = 6 s</p>
Time factor (1...255) Time for one step in partial range 2	1 to 255, 10	<p>For each step in the partial ranges, a time can be parameterized. This time determines when the next step is reached or transmitted. Defines the time factor for partial range 2.</p> <p>Time = Base · Factor</p> <p>Preset value: 10 · 0.6 s = 6 s</p>
Start value (0...253) Start value < support value	0 to 253, 0	<p>Defines the start value.</p> <p>The start value must be less than the support value!</p>
Support value (1...254) support value < target value	1 to 254, 127	<p>Defines the support value.</p> <p>The support value must be less than the target value!</p>

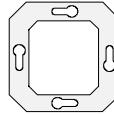

Target value (2...255)	2 to 255, 255	Defines the target value.
Rocker 2 see rocker 1! (depending on projected variant)		
Rocker 3 see rocker 1! (depending on projected variant)		
Rocker 4 see rocker 1! (depending on projected variant)		
Status of rocker 1		
Function of rocker 1 = "No function", "Switch", "Dimmer", "Blind/shutter" and "Universal value transmitter EIS 6"		
Indicate status object via	left and right status-LED left status-LED right status-LED inverted left and right status-LED inverted left status-LED inverted right status-LED left and right status-LED always ON left and right status-LED always OFF	Defines the function of the status-LED.
Status of rocker 2 see status of rocker 1 (depending on projected variant)		
Status of rocker 3 see status of rocker 1! (depending on projected variant)		
Status of rocker 4 see status of rocker 1! (depending on projected variant)		

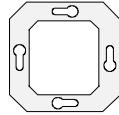

Software information

▸ Dimmer function

For correct functioning of the status-LED during status reporting, the dimming connected actuator must transmit its status back to the switching object in case of key function or back to the status object in case of rocker function (set Ü flag).

For correct functioning in case of key function (brighter / darker (TOGGLE)), the connected dimming actuator must also transmit its status back to the switching object.

With key function and rocker function, only the switching object is followed up internally and externally. The dimming object (dimming direction) is followed up only internally. When extensions are used (2 or more dimming actuators dimming one lamp), the dimming direction is therefore not always toggled when the key is pressed again.

For two-sided operation with key function, the objects of the combined keys must be assigned the same group address.

▸ Shutter / blind function

To realize a "complete" shutter / blind function (UP and DOWN) with key function, the step objects and the move objects of the combined keys must be assigned the same group address.

▸ Value transmitter EIS 6 / analog value transmitter function

During a value adjustment by means of a long key-press, the newly-set values are stored in the RAM only, which means that these values are replaced after a voltage failure or a bus reset by the original ETS-programmed values.

▸ Status indication

The status-LED (when status indication is active) indicates the current status of the switching object for key operation. If a key is pressed (e.g. ON) and if the push sensor does not receive a positive acknowledge signal (IACK) from the addressed actuator, the object status will be updated and the corresponding status-LED lights up.

• Disable object

If the polarity of the disable object is parameterized as "inverted (disable = 0; enable = 1)", the push sensor will be disabled immediately on return of bus voltage or a download. In this case, the Push sensor 2 F-line is enabled only after the object value of the disable object is equal to "1".