

## LV dimming insert with pressure/2-way switch

Order No. : 1183 00

## LV dimming insert with pressure/2-way switch

Order No. : 1183 ..

## LV dimming insert with pressure/2-way switch

Order No. : 0306 ..

## Operating instructions

### 1 Safety instructions

Electrical equipment may only be installed and fitted by electrically skilled persons.

Serious injuries, fire or property damage possible. Please read and follow manual fully.

Danger of electric shock. Always disconnect before carrying out work on the device or load. At the same time, take into account all circuit breakers that supply dangerous voltage to the device or load.

Danger of electric shock. Device is not suitable for disconnection from supply voltage.

Fire hazard. For operation with inductive transformers, each transformer must be fused on the primary side in accordance with the manufacturer's instructions. Only safety transformers according to EN 61558-2-6 may be used.

Do not connect any LED or compact fluorescent lamps that are not specifically suitable for dimming. Device can be damaged.

Do not connect any lights with integrated dimmers. Device can be damaged.

These instructions are an integral part of the product, and must remain with the end customer.

### 2 Device components

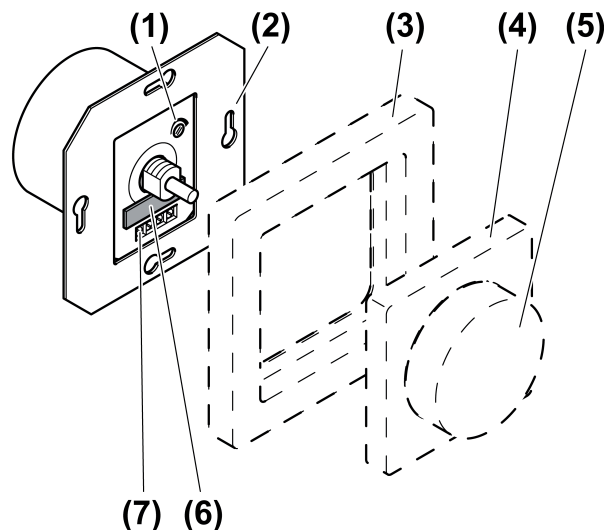





Figure 1: Device components

- (1) Basic brightness adjuster
- (2) Dimmer
- (3) Frame
- (4) Central plate
- (5) Control button
- (6) Fuse holder
- (7) Screw terminals

## 3 Function

### Intended use

- Switching and dimming of incandescent lamps, HV halogen lamps as well as dimmable inductive transformers with halogen or LED lamps.
- Switching and dimming dimmable HV-LED lamps or compact fluorescent lamps.
- Installation in appliance box according to DIN 49073.
-  No mixed-load operation of HV LED and compact fluorescent lamps. All other specified load types can be used in mixed-load operation.
-  No operation with Tronic transformers.
-  HV-LED and compact fluorescent lamps generate high pulsed currents, when they are operated in the leading edge phase control. Depending on the design and power rating of these lamps, the connected load of the specified values could vary.

### Product characteristics

- Phase cut-on dimming principle
- Short-circuit protection through fine-wire fuse
- Electronic over-temperature protection
- Changeover switch possible in combination with two dimmers
- Operation on 60 Hz mains possible
- It is possible to increase power by means of power packs
-  Flickering of the connected lamps due to undershoot of the specified minimum load or through centralised pulses from the power stations and soft humming of the device due to the radio interference suppressor. These are not device faults.

## 4 Operation

### Switch light

- Press the control button.

### Adjust the brightness

Light is switched on.

- Turn the control button in the clockwise direction.  
The light gets brighter up to maximum brightness.
- Turn the control button in the anti-clockwise direction.  
Light gets darker to minimum brightness.

## 5 Information for electrically skilled persons

### 5.1 Fitting and electrical connection



#### **DANGER!**

**Electrical shock when live parts are touched.**

**Electrical shocks can be fatal.**

**Before carrying out work on the device or load, disengage all the corresponding circuit breakers. Cover up live parts in the working environment.**

---

## Connecting and mounting the dimmer

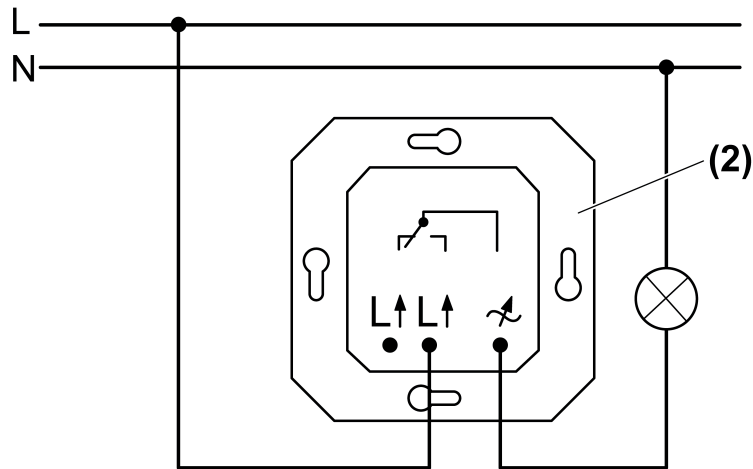

Figure 2: Connection diagram

- Connect the dimmer (2) according to the connection diagram (Figure 2).
- ❗ HV-LED lamps and compact fluorescent lamps: Only connect lamps of one manufacturer and of the same type.
- ❗ Connect 16 A maximum of 300 W HV LED lamps or compact fluorescent lamps per circuit breaker.
- Mount the dimmer in the accessory socket. Terminals must be at the bottom.
- Mount the frame and the central plate. Attach the control button.

## Connection in changeover switch

- ❗ No changeover switch possible with two dimmers.

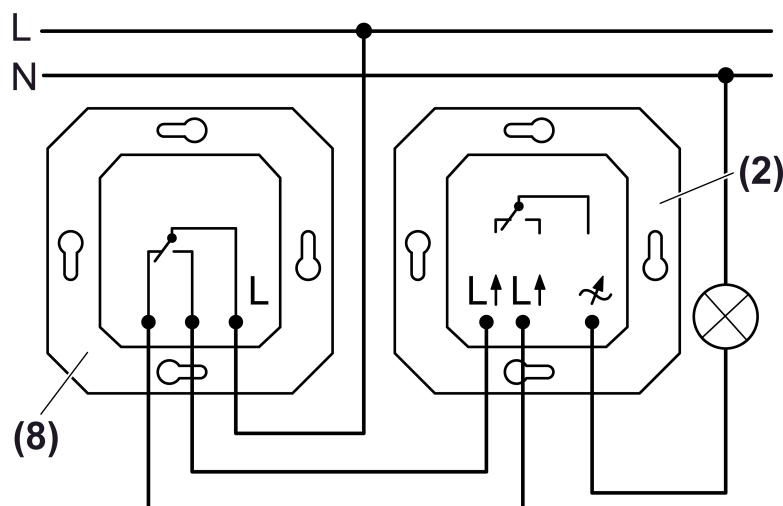

Figure 3: Changeover switch

- Connect the dimmer (2) and the changeover switch (8) according to the connection diagram (Figure 3).

## 5.2 Commissioning

### Adjusting basic brightness

The basic brightness can be set by an electrically skilled person as required, if, e.g. the light flickers at low brightness or to compensate for differences in brightness.



#### **DANGER!**

**Electrical shock when live parts are touched.**

**Electrical shocks can be fatal.**

**Use only insulated tools to set the basic brightness! Cover up live parts in the working environment.**

The device is connected as described above and fitted in an appliance box. The frame, central plate and control button are not fitted.

- Switch on mains voltage.
- Press the rotary axle to switch on the lighting and turn it left to the minimum brightness.
- Adjust basic brightness by turning the adjuster (1) (Figure 1).
- ⓘ According to EN 60669-2-1 (01.2000), lamp brightness should be detectable over the whole load area, with darkness at – 10 % rated voltage.
- Switch off the mains voltage.
- Mount the frame and the central plate. Attach the control button.
- Switch on mains voltage again.

## 6 Appendix

### 6.1 Technical data

Rated voltage	AC 230 / 240 V ~
Mains frequency	50 / 60 Hz
Ambient temperature	+5 ... +25 °C
Connected load at 25 °C	
ⓘ Operate inductive transformers with at least 85% nominal load.	
ⓘ Power specifications including transformer power dissipation.	
Incandescent lamps	20 ... 500 W
HV halogen lamps	20 ... 500 W
HV-LED lamps	typical 3 ... 100 W
Compact fl lamp.	typical 3 ... 100 W
Inductive transformers	20 ... 500 VA

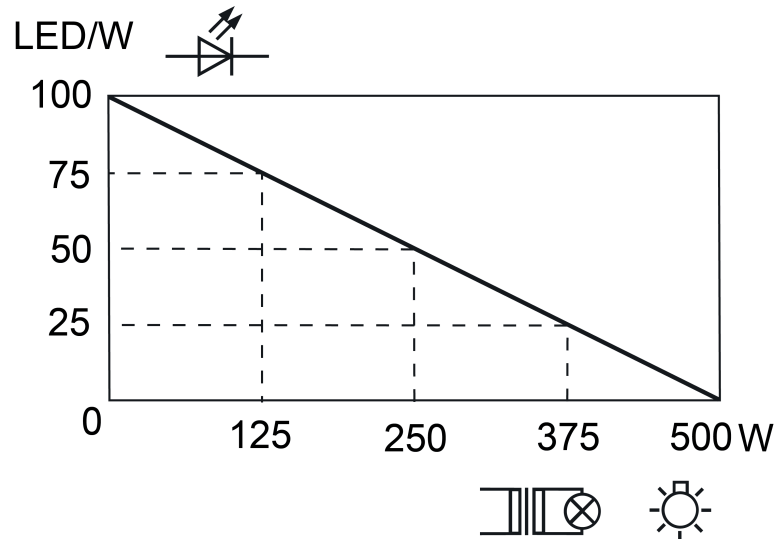

Figure 4

- i** Mixed-load operation of LED lamps or compact fluorescent lamps with other permissible loads possible. Note load curve (Figure 4).

Power reduction	
per 5°C in excess of 25°C	-10 %
when installed in wooden or dry construction walls	-15 %
when installed in multiple combinations	-20 %
Power boosters	See power booster instructions
Connection	
single stranded	max. 4 mm <sup>2</sup>
Fine-wire fuse	D 3.15 H 250



The icons used to label the dimmer load show the load type that can be connected to a dimmer and the electric behaviour of a load: R = ohmic, L = inductive, HV LED = dimmable HV-LED lamps

## 6.2 Troubleshooting

### Connected lamps switch off in the lowest dimming position or flicker

Cause: The set minimum brightness is too low.

Increase minimum brightness.

### Connected lamps flicker

Cause: Lamps are not dimmable.

Check manufacturer's instructions.

Exchange lamps for another type.

### Connected lamps do not switch on in the lowest dimming position or only after a delay

Cause: The set minimum brightness is too low.

Increase minimum brightness.

### Connected lamps in the lowest dimming position are too bright; dimming range is too small

Cause 1: The set minimum brightness is too high.

Reduce minimum brightness.

Cause 2: Dimming principle leading edge phase control does not optimally match the connected HV LED or compact fluorescent lamps.

Exchange lamps for another type.

**The device switches the load off and only on again after some time.**

Cause: overheating protection has tripped.

Reduce the connected load.

Check the installation situation.

**The device switches the load off and cannot be switched on again.**

Cause: short-circuit protection has tripped.

Eliminate short-circuit.

Replace the fine-wire fuse, replacement fuse in the fuse holder. Use only original fuses.

## 6.3 Warranty

The warranty is provided in accordance with statutory requirements via the specialist trade.

Please submit or send faulty devices postage paid together with an error description to your responsible salesperson (specialist trade/installation company/electrical specialist trade). They will forward the devices to the Gira Service Center.

**Gira**  
**Giersiepen GmbH & Co. KG**  
Elektro-Installations-  
Systeme

Industriegebiet Mermbach  
Dahlienstraße  
42477 Radevormwald

Postfach 12 20  
42461 Radevormwald

Deutschland

Tel +49(0)21 95 - 602-0  
Fax +49(0)21 95 - 602-191

[www.gira.de](http://www.gira.de)  
[info@gira.de](mailto:info@gira.de)