

Operating instructions

Blind actuator 4-gang 230 V AC
Order no. 1039 00

Blind actuator 2-gang 230 V AC
Order no. 2152 00

Blind actuator 4-gang 24 V DC
Order no. 2154 00

Blind actuator 4-gang 230 V AC
Order no. 2160 00

Blind actuator 8-gang 230 V AC
Order no. 2161 00



Table of Contents

1	Safety instructions	3
2	Device components	3
3	System information	4
4	Intended use	4
5	Product characteristics	4
6	Operation	5
7	Information for electrically skilled persons	8
7.1	Mounting	8
7.2	Connect bus line	8
7.3	DC 24 V Venetian blind actuator: electrical connection	9
7.4	Shutter actuators AC 230 V and roller shutter actuator: electrical connection.....	10
7.5	Commissioning	12
8	Technical data	14
9	Troubleshooting	16
10	Warranty	18

1 Safety instructions



Electrical devices may only be mounted and connected by electrically skilled persons.

Serious injuries, fire or property damage are possible. Please read and follow the manual fully.

Danger of electric shock. Always disconnect before carrying out work on the device or load. In so doing, take all the circuit breakers into account, which support dangerous voltages to the device and or load.

Risk of injury. Use the device only for controlling Venetian blind and roller shutter motors or awnings. Do not use it to switch other loads.

For parallel connection of several motors to an output it is essential to observe the corresponding instructions of the manufacturing company, and to use a cut-off relay if necessary. The motors may be destroyed.

Use only Venetian blind motors with mechanical or electronic limit switches. Check the limit switches for correct mastering. Observe the information on the motors from the manufacturing company. Device can be damaged.

Danger of electric shock on the SELV/PELV installation. Do not connect loads for mains voltage and SELV/PELV together to the device.

This manual is an integral part of the product, and must remain with the customer.

2 Device components

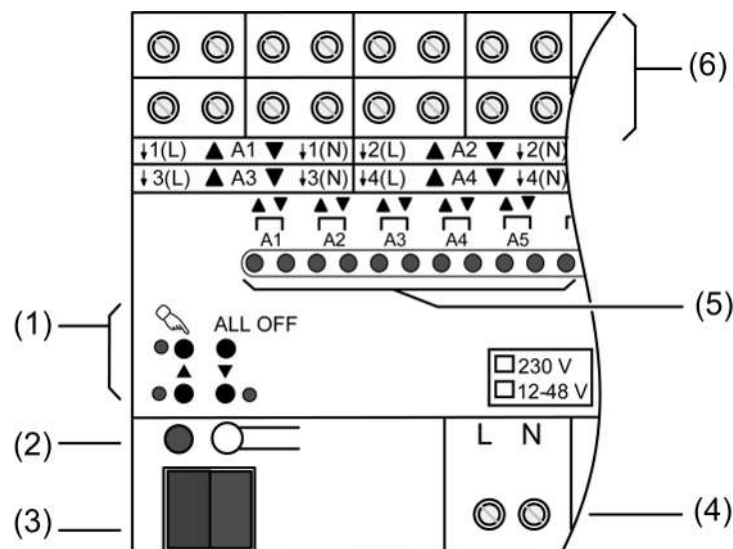

Figure 1

- (1) Button field for manual operation
- (2) Programming button and LEDs
- (3) KNX connection
- (4) Connection for mains supply
- (5) Status LEDs for outputs

- (6) Connection for Venetian blind motors

3 System information

System information

This device is a product of the KNX system and complies with the KNX directives. Detailed technical knowledge obtained in KNX training courses is a prerequisite to proper understanding.

The function of this device depends upon the software. Detailed information on loadable software and attainable functionality as well as the software itself can be obtained from the manufacturer's product database. Planning, installation and commissioning of the device are carried out with the aid of KNX-certified software. The latest versions of product database and the technical descriptions are available on our website.

4 Intended use

- Switching of electrically driven Venetian blinds, shutters, awnings and similar hangings for AC 230 V mains voltage or DC 12...48 V extra-low voltage.
- Mounting on DIN rail according to DIN EN 60715 in sub-distribution unit

5 Product characteristics

- Outputs can be operated manually, construction site mode
- Blind/shutter position directly controllable
- Acknowledgement of the blind/shutter position in bus and manual mode
- Safety functions: 3 independent wind alarms, rain alarm, frost alarm
- Integration into the temperature management of the building
- Disabling of individual outputs manually or by bus

i Delivery state: Outputs can be operated using button field, construction site mode.

Only Venetian blind actuators:

- Automatic operation time detection for 230 V motors can be set
- Slat position directly controllable
- Acknowledgement of movement state and slat position in bus and manual mode
- Scene function
- "Top" and "Bottom" forced position via higher-level controller
- Sun protection function

6 Operation

Operating elements

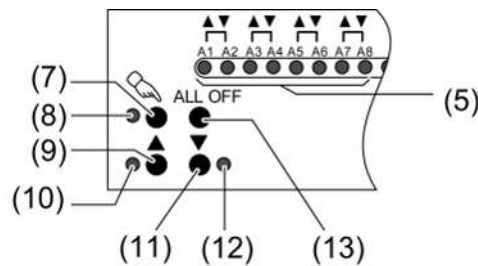

Figure 2

- (5) Status LEDs for outputs
- (7) Button – Manual operation
- (8) LED – on: continuous manual mode
- (9) Button ▲: move hanging upwards / stop
- (10) LED ▲ – on: hanging moves up, manual mode
- (11) Button ▼: move hanging downwards / stop
- (12) LED ▼ – on: hanging moves down, manual mode
- (13) Button **ALL OFF**: stop all hangings

In operation with the button field the device distinguishes between a short and a long press.

- Short: Pressing for less than 1 second
- Long: Pressing for between 1 and 5 seconds

Status indication

The status LED A1... (5) indicate the states of the outputs.

- Off: Output switched off
- On: Output switched on
- Flashes slowly: Output in manual mode
- Flashes quickly: Output disabled via continuous manual mode

Operating modes

- Bus operation: operation via push-button sensors or other bus devices
- Temporary manual operation mode: manual operation locally with button field, automatic return to bus operation
- Permanent manual operation mode: exclusively manual operation on the device

No bus operation is possible in manual mode.

No manual mode is possible in case of bus failure.



- i** After a bus failure and restoration the device switches to bus operation.
- i** After a power failure and restoration the device switches to bus operation.
- i** The manual mode can be disabled in ongoing operation via a bus telegram.

Priorities

- Highest priority: manual mode
- 2th priority: forced position
- 3rd priority: safety function
- 4th priority: sun protection
- Lowest priority: bus mode: moving up/down, slat positioning, scenes, positioning

Switching on temporary manual operation mode

Operation using the button field is programmed and not disabled.

- Press the  button briefly.
LEDs A1 flash, LED  remains off.

- i** After 5 seconds without actuating a button, the actuator returns automatically to bus operation.

Switching off temporary manual operation mode



The device is in temporary manual operation mode.

- No button has been actuated for 5 seconds.
- or -
- Press the  button briefly as many times as necessary until the actuator exits temporary manual operation mode.
LEDs A1... no longer flash, but rather indicate the output status.

Depending on the programming, the hangings move to the position that is active after the manual mode is switched off, e.g. to the forced position, safety or sun protection position.



Switching on permanent manual operation mode

Operation using the button field is programmed and not disabled.

- Press the  button for at least 5 seconds.
LED  is illuminated, LEDs A1 flash, continuous manual mode is switched on.

Switching off permanent manual operation mode







The device is in permanent manual operation mode.

- Press the  button for at least 5 seconds.
LED  is off, bus operation is switched on.

Depending on the programming, the hangings move to the position that is active after the manual mode is switched off, e.g. to the forced position, safety or sun protection position.

Operating the outputs

The device is in permanent or temporary manual operation mode.

- Press the button  briefly as many times as necessary until the desired output is selected.
LEDs of the selected output **A1...** flash.
The LEDs  and  indicate the status.
- Operate output with  button or  button.
Short: Stop hanging.
Long: Move hanging upwards/downwards.
The selected hanging executes the corresponding commands.
The LEDs  and  indicate the status.

 Short-term manual mode: After running through all of the outputs the device exits manual mode after another brief actuation.



Stop all hangings

The device is in permanent manual operation mode.

- Press the **ALL OFF** button.
All outputs switch off; all hangings stop moving.

Disabling individual outputs

The device is in permanent manual operation mode.

- Press the button  briefly as many times as necessary until the desired output is selected.
The status LEDs of the selected output **A1...** flash.
- Press buttons  and  simultaneously for at least 5 seconds.
Selected output **A1...** is disabled.
The status LEDs of the selected output **A1...** flash quickly.
- Activate bus mode (see section Deactivating permanent manual control).

 A disabled output can be operated in manual mode.

-  When a disabled output is selected in manual mode, the corresponding status LEDs flash twice briefly at intervals.

Re-enabling outputs

The device is in permanent manual operation mode.

- Press the button  briefly as many times as necessary until the desired output is selected.
The status LEDs of the selected output A1... flash twice briefly at time intervals.
- Press buttons ▲ and ▼ simultaneously for at least 5 seconds.
Selected output A1... is enabled.
LEDs of the selected output A1... flash slowly.
- Activate bus mode (see section Deactivating permanent manual control).

7 Information for electrically skilled persons

7.1 Mounting

Mounting the device



DANGER!

Electric shock when live parts are touched.

Electric shocks can be fatal.

Always disconnect before carrying out work on the device or load. For this, switch off all corresponding circuit breakers, secure against being switched on again and check that there is no voltage. Cover up adjacent live parts.



DANGER!

Danger of destruction if several motors are connected in parallel to one output.

Limit switch contacts can weld together and motors, blinds/shutters and the venetian blind actuator can be destroyed.

Observe the manufacturer's instructions. Use cutoff relay if necessary!

Observe the temperature range. Ensure sufficient cooling.

- Mount the device on DIN rail. Output terminals must be at the top.

7.2 Connect bus line

- Connect bus line with KNX device connection terminal observing the correct polarity (see figure 3), (see figure 4).

- Attach the cover cap to the KNX connection as protection against hazardous voltages.

7.3 DC 24 V Venetian blind actuator: electrical connection

Connecting the device

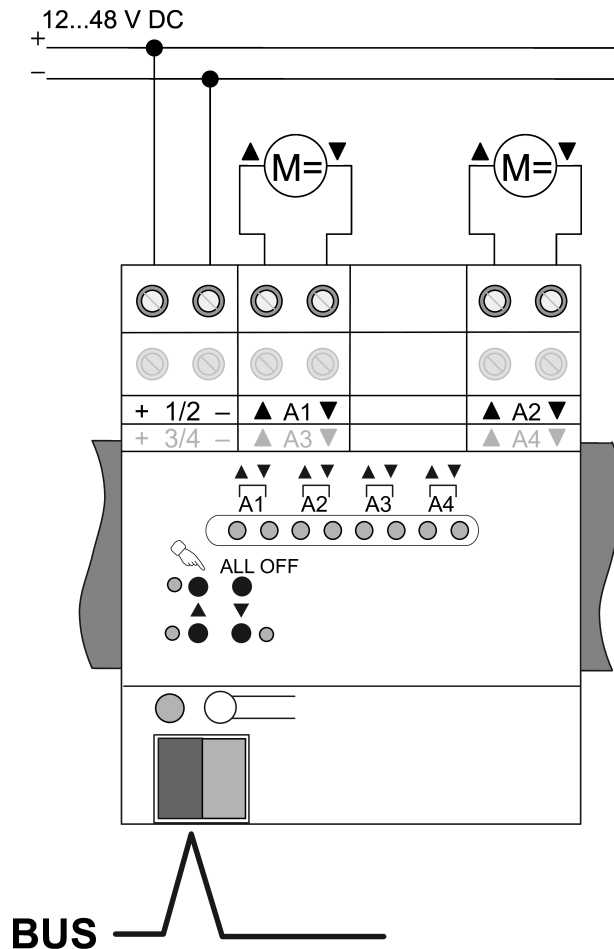

Image 3: Connection example for DC Venetian blind actuator

Only for DC motors 12...48 V. Observe the admissible load ratings.

Terminals **1/2** supply power to the device electronics and outputs **A1** and **A2**. For operation of the actuator it is necessary to connect an external 24 V DC power supply to **1/2**.

Terminals **3/4** supply power to outputs **A3** and **A4**.

The supply voltages must be designed in such a way that a safe and reliable operating voltage is provided under all load conditions – especially when the motors are first switched on.

Do not connect any AC voltage.

- Connect power supply to terminals **1/2** or **3/4** (see figure 3).
- Connect motors to load terminals **A1** ... **A4** (see figure 3).

- i** Drives for venting louvers or windows must be connected in such a way that they open in travel direction "UP " and close in travel direction "DOWN".

7.4 Shutter actuators AC 230 V and roller shutter actuator: electrical connection

Connecting the device without automatic operation time detection

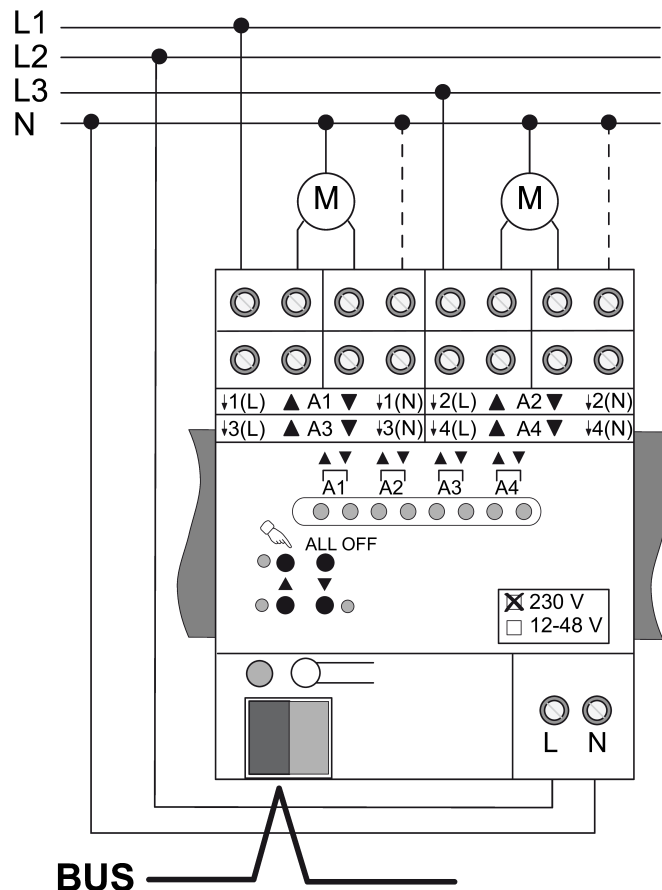

Image 4: Connection of bus and mains voltage supply

- Connect mains voltage supply (see figure 4).
 - Connecting the motors (see figure 5).
 - Mark **230 V** use on label (see figure 5).
- i** The N conductor connections (14) serve only to detect the operation time and do not provide any N potential.
- i** If motors with high-impedance inputs are connected, then the corresponding N conductor can be connected. The associated output must not be under current for a longer period without interruption due to retriggering. This can lead to impermissible heating of the device. Observe maximum duty cycle (see chapter "Technical data").

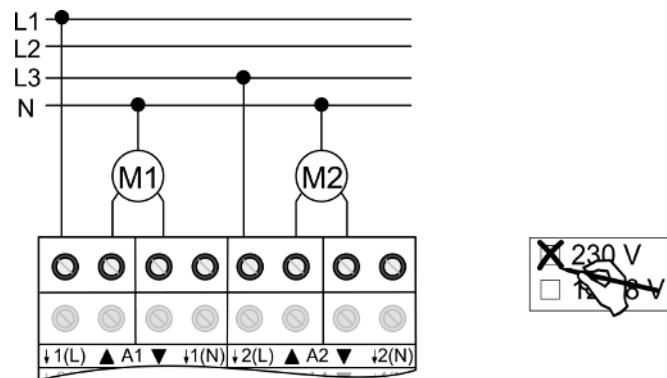

Image 5: Motor connection without automatic operation time detection

Connecting the device with automatic operation time detection

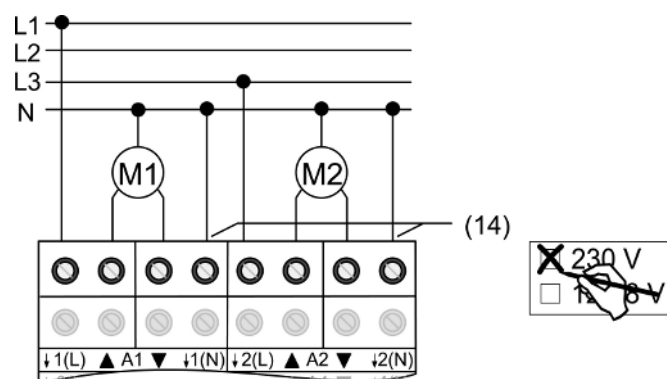

Image 6: Motor connection with automatic operation time detection

i Not for roller shutter actuator.

When appropriately programmed and wired, the Venetian blind actuator detects the operation time of the individual hangings and saves them. The actuator measures the voltage at the outputs against the connected neutral conductor (14), and uses it to determine the end positions. During operation the Venetian blind actuator adjusts itself to changed operation times, e.g. due to ageing of the motors.

i The automatic operation time detection cannot be used for 110 V AC motors, DC motors, motors with electronic limit switches, or for motors that are connected to the outputs using cutoff relays.

i Only for 230 V AC motors with mechanical limit switches.

Automatic operation time detection is activated in the application software.

Hangings are not disabled.

- Connect mains voltage supply (see figure 4).

i Connect only one motor per output.

- Connecting the motor (see figure 6).
- Connect the N conductor of the corresponding motor to the N conductor terminals (14) (see figure 6). Note RCCB wiring.
- Mark **230 V** use on label (see figure 6).

- i** The N conductor connections for the individual outputs and mains voltage connection are not connected internally.
- i** If an output is energised without interruption for a prolonged time due to retriggering, the device may heat up excessively. Observe maximum duty cycle (see chapter "Technical data").
- i** The automatic operation time detection is performed during commissioning and the determined operation time is saved permanently.

Connecting the device for 12...48 V DC motors

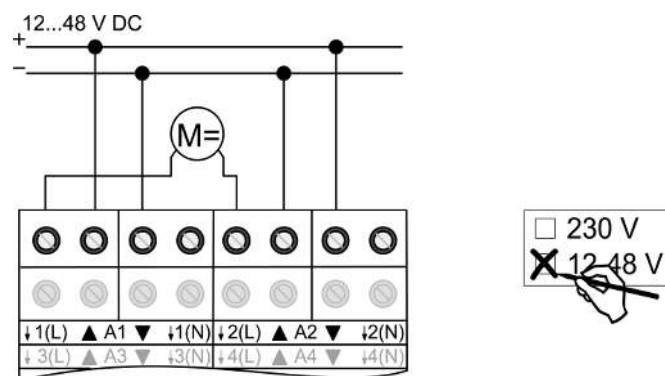

Image 7: Connection of DC motors

- i** Not for roller shutter actuator.

The adjacent Venetian blind outputs **A1** and **A2** ... **A7** and **A8** can be used jointly to switch a DC motor.

The Venetian blind drive actuator is programmed as a DC device.

- Connect mains voltage supply (see figure 4).
- i** Connect only one motor per output.
- Connecting the motors (see figure 7).
- Mark **12-48 V** use on label (see figure 7).
- i** For DC operation, manual mode for outputs **A2**, **A4**... is without function. The status LEDs indicate the relay states.

7.5 Commissioning

Measuring the hanging and slat operation time

The blind/shutter travelling time is important for position and scene runs. For slatted Venetian blinds, the slat adjusting time is by design part of the overall blind travelling time. The opening angle of the slats is therefore set as the operation time between the positions "Open" and "Closed".

The upwards travel generally lasts longer than the downwards travel, and is taken into account as the operation time extension in %.

- Measure upwards and downwards operation time of the hanging.
- Measure slat adjusting time between "Open" and "Closed".
- Enter the measured values in the parameter setting – Downwards travel in seconds and operation time extension in percent.
- i** In the case of automatic operation time detection, no measurement of the hanging operation times is performed.
- i** Automatic measurement of the slat adjusting time is not possible.

Load the address and the application software

- Switch on the bus voltage.
- Assign physical address.
- Load the application software into the device.
- Note the physical address on the device label.

Performing a reference movement

The Venetian blind drive actuator can only move to scenes and directly called positions if it has saved the positions of the hangings. To do this, each output has to perform a reference run.

- Move hangings to the upper end position.
- Wait until the output relay and the limit switch have switched off.
- i** The venetian blind actuator does not save the hangings position permanently. After a power failure and restoration it carries out another reference run.
- i** Without a reference run, the Venetian blind actuator generates an internal "Invalid position" message for each output that can be read out.

Automatic operation time detection: save operation times

- i** Not for roller shutter actuator.
- i** Only for 230 V motors.

When operation time detection is activated, the device can only set positions and scenes when it has saved the operation times. The operation times must be saved during interference-free conditions, i.e. no additional operations, no wind, no snow, no obstructions.

Automatic operation time detection is activated in the application software.

The associated N conductors are connected for the outputs in question (see figure 6).

- i** Teaching runs must be performed only in manual mode or using commissioning software.
- Move hangings to the upper end position (see chapter "Perform reference run").

Upper end position has been reached:

- Move hangings to lower end position in manual mode.
- Move hangings to upper end position in manual mode.

Operation times have been saved.

- i** The Venetian blind actuator saves the operation times permanently.
- i** Without saved operation times the Venetian blind actuator generates an internal "Invalid position" message for each output that can be read out.
- i** During operation the Venetian blind actuator adjusts itself to changed blind travelling times, e.g. caused by ageing of the motors. The slat operation time is taken into account here. The changed times are only saved permanently in continuous manual mode.

8 Technical data

Supply

Rated voltage

Order no. 2154 00	DC 12 ... 48 V =
Order no. 2160 00	AC 230 / 240 V ~
Order no. 2152 00	AC 230 / 240 V ~
Order no. 1039 00	AC 230 / 240 V ~
Order no. 2161 00	AC 230 / 240 V ~

Mains frequency

Order no. 2154 00	—
Order no. 2160 00	50 / 60 Hz
Order no. 2152 00	50 / 60 Hz
Order no. 1039 00	50 / 60 Hz
Order no. 2161 00	50 / 60 Hz

Power loss

Order no. 2154 00	max. 1 W
Order no. 2160 00	max. 4.5 W
Order no. 2152 00	max. 4.5 W
Order no. 1039 00	max. 4.5 W
Order no. 2161 00	max. 6 W

Ambient conditions

Ambient temperature	-5 ... +45 °C
Storage/transport temperature	-25 ... +70 °C

Installation width

Order no. 2154 00	72 mm / 4 HP
Order no. 2160 00	72 mm / 4 HP

Order no. 2152 00	72 mm / 4 HP
Order no. 1039 00	72 mm / 4 HP
Order no. 2161 00	144 mm / 8 HP
Weight	
Order no. 2154 00	approx. 300 g
Order no. 2160 00	approx. 300 g
Order no. 2152 00	approx. 250 g
Order no. 1039 00	approx. 300 g
Order no. 2161 00	approx. 550 g
Venetian blind outputs	
Minimum switching current AC	100 mA
Switching current AC 250 V	
Order no. 2154 00	--
Order no. 2160 00	AC 6 A
Order no. 2152 00	AC 6 A
Order no. 1039 00	AC 6 A
Order no. 2161 00	AC 6 A
Switching current DC 12 V	
Order no. 2154 00	6 A
Order no. 2160 00	--
Order no. 2152 00	6 A
Order no. 1039 00	6 A
Order no. 2161 00	6 A
Switching current DC 24 V	
Order no. 2154 00	6 A
Order no. 2160 00	--
Order no. 2152 00	6 A
Order no. 1039 00	6 A
Order no. 2161 00	6 A
Switching current DC 48 V	
Order no. 2154 00	3 A
Order no. 2160 00	--
Order no. 2152 00	3 A
Order no. 1039 00	3 A
Order no. 2161 00	3 A
Blind/shutter travelling time	max. 20 min
Duty cycle	max. 50% (cycle time ≤ 40 min)
Automatic operation time adaptation	
Order no. 2154 00	--

Order no. 2160 00	max. 20% of the blind/shutter travelling time
Order no. 2152 00	max. 20% of the blind/shutter travelling time
Order no. 1039 00	max. 20% of the blind/shutter travelling time
Order no. 2161 00	max. 20% of the blind/shutter travelling time

Connections supply and load

Connection mode

Screw terminal

Clampable conductor cross-section (see figure 8)



Image 8: Clampable conductor cross-section

KNX

KNX medium

TP 1

Commissioning mode

S-mode

Rated voltage KNX

DC 21 ... 32 V SELV

Power consumption KNX

typ. 150 mW

Connection mode KNX

Standard device connection terminal

9 Troubleshooting

Manual control with button field not possible

Cause 1: Manual control has not been programmed.

Program manual control.

Cause 2: Manual control via bus disabled.

Enable manual control.

Output cannot be operated

Cause 1: Manual control has not been programmed.

Reprogram device.

Cause 2: Manual control via bus disabled.

Enable manual control.

None of the outputs can be operated

Cause 1: All of the outputs are disabled.

Cancel disabling.

Cause 2: Manual mode active.

Deactivate manual mode (switch off continuous manual mode).

Cause 3: Application software missing or faulty.

Check programming and correct.

Cause 4: Application software has been stopped, programming LED is flashing.

Disconnect device from the bus and mains, switch on again after 10 seconds.

Position- and scene runs are not executed or executed improperly

Cause 1: Sun protection, safety function or manual mode is activated.

As long as higher-order functions are active, no position or scene runs are possible.

Cause 2: No operation time saved.

Save operation times (see chapter "Automatic operation time detection: save operation times").

i Without saved operation times the venetian blind actuator moves the hangings upwards or downwards for position and scene runs – depending on whether the hangings are in the upper or lower half.

Cause 3: Automatic operation time detection is activated and N conductor is not connected.

Correct electrical connection.

- or -

Deactivate automatic operation time detection.

Cause 4: Automatic operation time detection is activated, but the switching voltage is < 230 V or motors with electronic limit switches are being used.

Deactivate automatic operation time detection.

Correct electrical connection and remove N conductor.

Hanging does not move to end position, position and scene runs faulty

Cause: Blind/shutter travelling time has been set incorrectly.

Correct blind/shutter travelling time.

10 Warranty

The warranty is provided in accordance with statutory requirements via the specialist trade. Please submit or send faulty devices postage paid together with an error description to your responsible salesperson (specialist trade/installation company/electrical specialist trade). They will forward the devices to the Gira Service Center.

Gira
Giersiepen GmbH & Co. KG
Elektro-Installations-
Systeme

Industriegebiet Mermbach
Dahlienstraße
42477 Radevormwald

Postfach 12 20
42461 Radevormwald

Deutschland

Tel +49(0)21 95 - 602-0
Fax +49(0)21 95 - 602-191

www.gira.de
info@gira.de