

Residual current socket 10 mA

Order No.: 0358 ..

Residual current socket 30 mA

Order No.: 0359 ..

1. Operating description

The operating principle of the residual current socket is identical to that of the residual current device. In a fault-free installation, in which no current is leaking to earth, the currents flowing to and back from cancel each other out in the core balance transformer and no tripping occurs.

However, should a partial current leak to earth due to a fault, the current flowing back from the load will be lower than that flowing to it. This difference in current will trip the leakage current socket within a maximum of 30 ms.

All units and cables which are connected to the residual current socket are covered by residual current protection. However, protection does not extend to the electrical installation upstream of the socket.

2. Circuit diagram

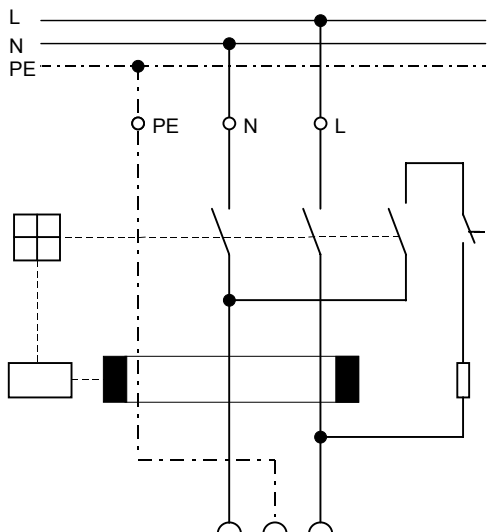

N.B.:
The protective measures of VDE 0100 must also be observed when using the residual current socket.

Protective wire guarded and led through the converter in opposite direction.

3. Connection diagram

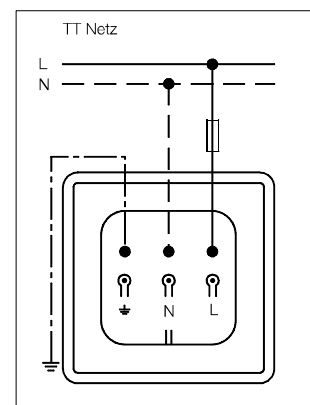
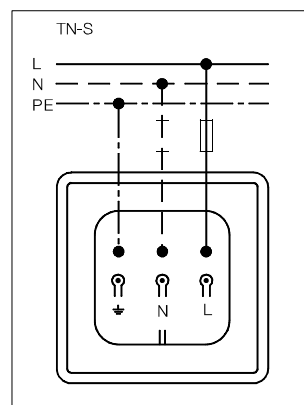
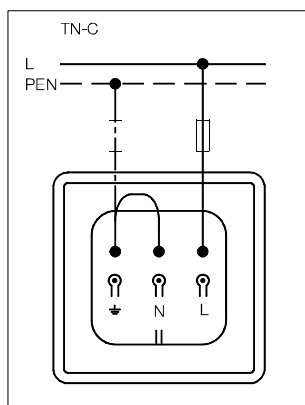

4. Installation

The residual current socket is mounted in a commercially-available sunken patress box with screws.
N.B.: Only a qualified electrician may install the residual current socket. The current installation instruction must be observed on installation.

5. Push-in terminals

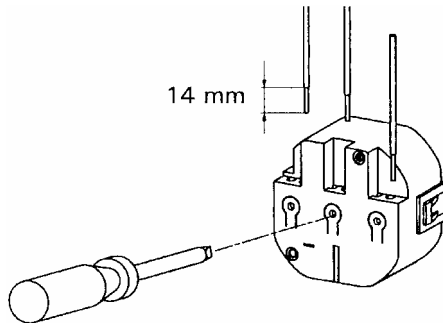

Press the lug to release the connecting leads.

6. Operating test

The operation of the residual current socket must be tested after installation. When the residual current socket is live and switched on („I“) it must trip when the test button („Test“) is pressed. This test should be carried out at least once per month, to guarantee perfect operation of the residual current socket in the case of a fault. The residual current socket must also be tested for perfect operation with a suitable test unit.

Equipment which trips the residual current socket during operation is faulty and must be inspected / repaired by an electrician.

The residual current socket itself must not be repaired.

7. Testing the protective provisions

Apart from operation, the effectiveness of the protective measure under the valid installation rules must be checked. The highest permissible earthing resistances are as follows for protection from indirect contact:

Highest permissible touch potential	Highest permissible earthing resistance at rated fault current	
	10 mA	30 mA
25 V	2.500 Ω	833 Ω
50 V	5.000 Ω	1.666 Ω

8. Technical data

Rated voltage:	230 V / 50 Hz
Rated current:	16 A
Rated fault current:	10 mA or 30 mA
Conductor size:	1,5 - 2,5 mm ² (Copper or aluminium conductors may be used)
VDE test under	DIN VDE 0662 / 0620
Ambient temperature:	- 25 °C ... + 40 °C

9. Theoretical method of operation of a residual current device on AC and pulsating DC current

The operating current I_B flowing to and back from the loads generates two magnetic field ϕ_B in the core balance transformer. These fields are reciprocally rectified and therefore cancel each other out.

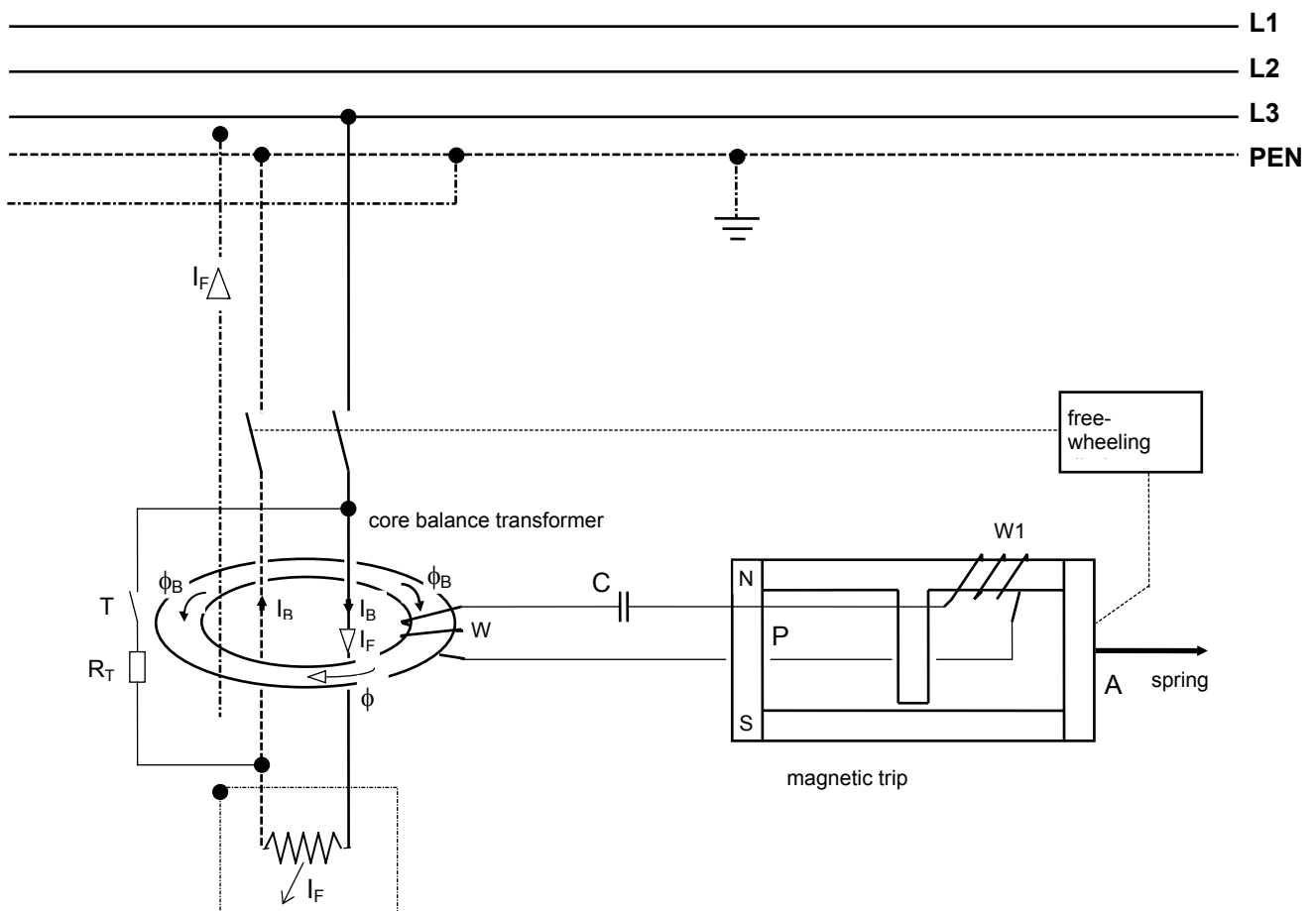

In the case of a fault, i.e. if a fault current I_F leaks to earth, and additional magnetic field ϕ_F is generated, inducing an AC current in the trip winding W of the core balance transformer which is fed to the magnetic trip.

The force of permanent magnet P retains the armature A of the magnetic trip. If winding $W1$ is excited by the AC voltage from the core balance transformer, an electro-magnetic field forms which acts against the field of the permanent magnet, weakening it. The armature spring is now strong enough to pull the armature away from the permanent magnet. The energy of the falling armature trips the residual current device.

In the case of pulsating DC fault currents, which change their magnitude but not their direction, the energy emitted by the trip winding W is considerably lower. The electromagnetic field generated by the current in winding $W1$ is thus usually too weak to override the permanent magnetic field and make the armature drop.

A condenser C is thus installed in the tripping circuit, with a capacity sufficient to form an oscillating circuit in conjunction with windings W and $W1$, with a natural frequency of 50 Hz. It is thus possible to aggregate the energy of the individual fault current surges and trip the residual current device correctly.

Acceptance of guarantee

We accept the guarantee in accordance with the corresponding legal provisions.

Please return the unit postage paid to our central service department giving a brief description of the fault:

Gira
Giersiepen GmbH & Co. KG
Service Center
Dahlienstrasse 12
D-42477 Radevormwald



The CE sign is a free trade sign addressed exclusively to the authorities and does not include any warranty of any properties.

Gira
Giersiepen GmbH & Co. KG
Postfach 1220
D-42461 Radevormwald

Telefon: +49 / 21 95 / 602 - 0
Telefax: +49 / 21 95 / 602 - 339
Internet: www.gira.de